

1

2

3

4

5

6

RevNo	Revision note	Date	Signature	Checked
-------	---------------	------	-----------	---------

A

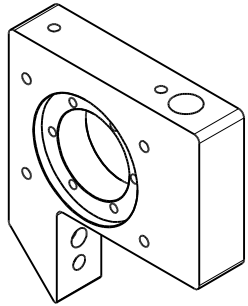

SCALE 1:3

B

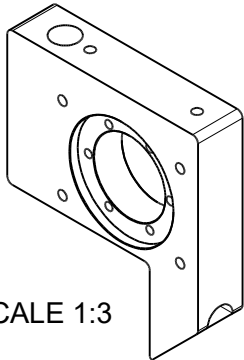

SCALE 1:3

C

D

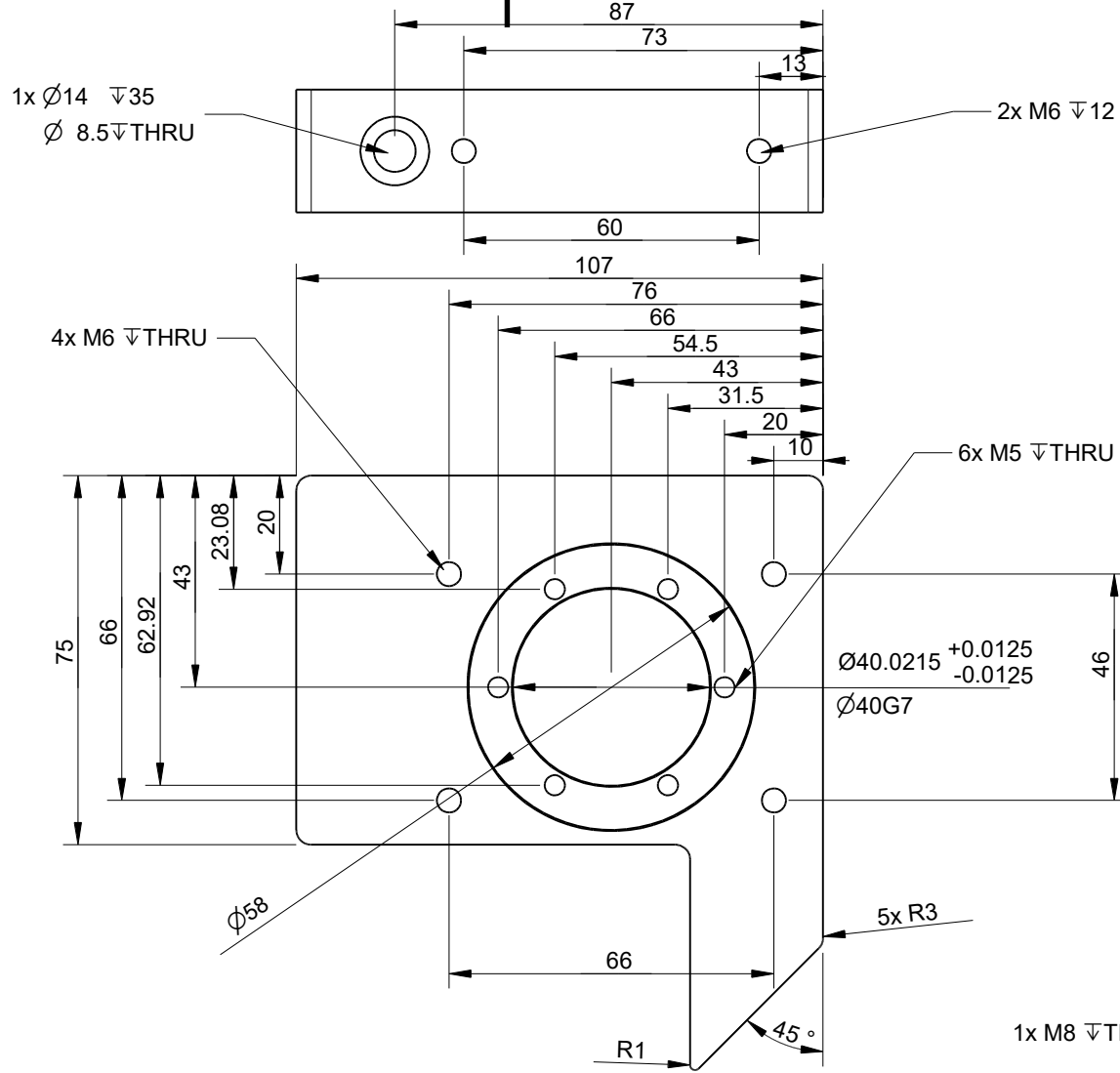

Units	mm
Tolerances	$\pm 0.1\text{mm}$ unless otherwise specified
Material	Alu 6082
Edges	Break all sharp edges 0.2mm
Tumbling	Yes
Surface finish	Anodize Clear/Blank

Itemref	Quantity	Title/Name, designation, material, dimension etc	Article No./Reference
Drawn by Cas Jansen	Checked by	Approved by - date	File name Date 28-9-2021
Scale 1:1.5			

# 1033

## www.damencnc.com

1033 DCNC LSM 80x80L Bearingplate for 25mm Ballscrew V2	Edition	Sheet 1 OF 1
--	---------	-----------------

1

2

3

4

5

6