

1

2

3

4

5

6

RevNo	Revision note		Date	Signature	Checked
-------	---------------	--	------	-----------	---------

A

A

B

B

M3x0.5 Metrix Coarse Thread Through

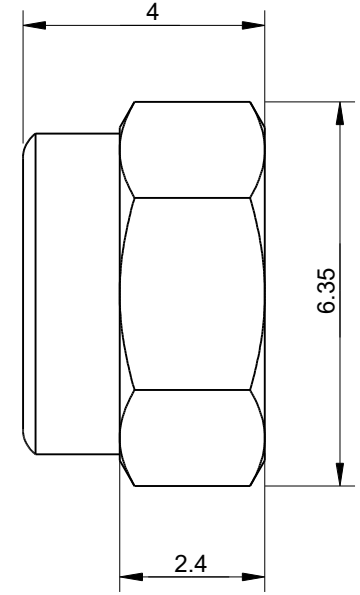
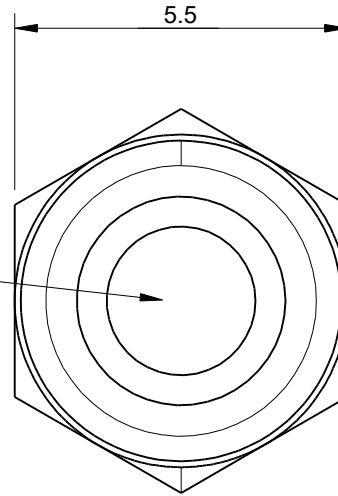

SCALE 1:1

C

C

D

D

Units	mm
Tolerances	± 0.1mm unless otherwise specified
Material	Steel
Surface finish	Galvanized

Itemref	Quantity	Title/Name, designation, material, dimension etc	Article No./Reference		
Drawn by Cas Jansen	Checked by	Approved by - date	File name	Date 12-11-2021	Scale 8:1
1365			www.damencnc.com		
			1365 M3 Locking nut DIN985		Edition

1

2

3

4

5

6