

1

2

3

4

5

6

RevNo

Revision note

Date

Signature

Checked

A

B

C

D

A

B

C

D

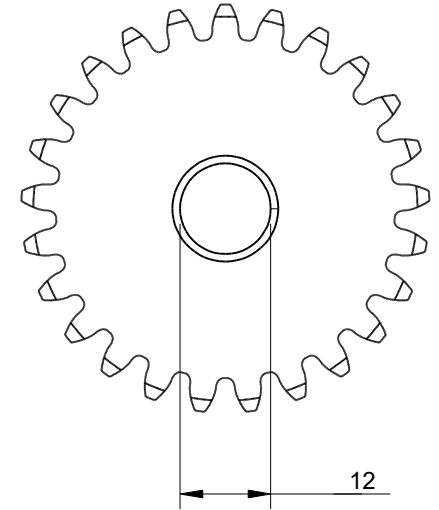
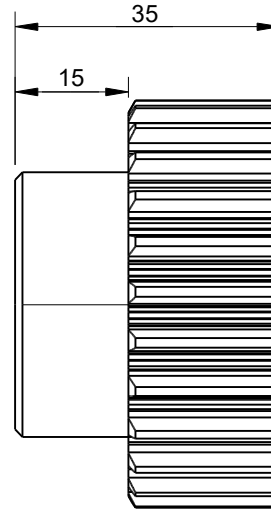
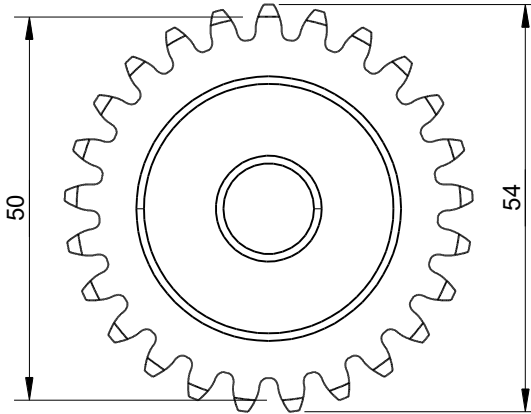
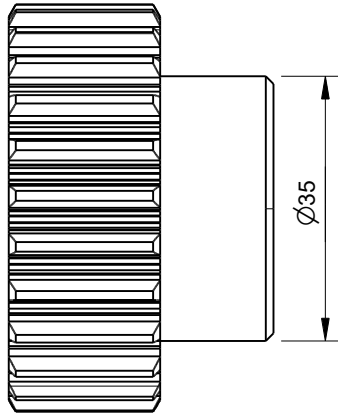
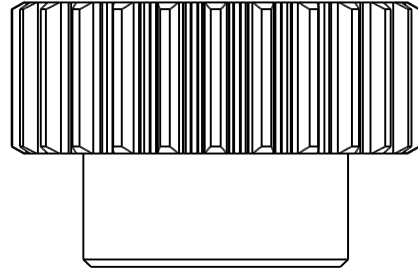
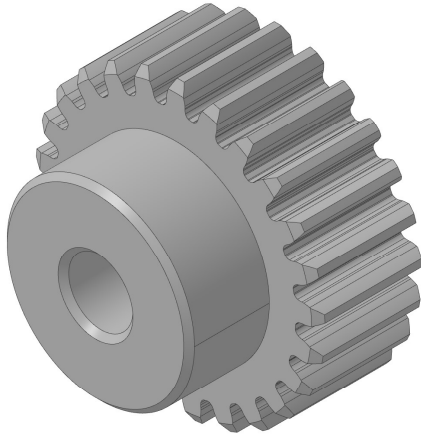

| | |
|---------------------|--------------------------------------|
| Number of Teeth (Z) | 25 |
| Module | 2 |
| Pressure Angle | 20° |
| Outside Ø | 54 |
| Pitch Ø | 50 |
| Root Ø | 45 |
| Bore Ø | 12 |
| Material | Steel C45 |
| Units | mm |
| Tolerances | +/- 0.1mm unless otherwise specified |

| | | | | | | |
|-------------------------|------------|--|-----------|-------------------|-----------------------|--|
| Itemref | Quantity | Title/Name, designation, material, dimension etc | | | Article No./Reference | |
| Drawn by Kevin Damen | Checked by | Approved by - date | File name | Date 29-4-2024 | Scale 1:1 | |

| | | | |
|-------------|--|---------|-----------------|
| 2836 | www.damencnc.com | | |
| | 2836 Module 2 Pinion, with 25 teeth | Edition | Sheet 1 OF 1 |

1

2

3

4

5

6