

SYNTESI® SHUT-OFF VALVE

This device separates the compressed air circuit from the main air supply. It is a three-way valve that relieves the downstream system in the closed position. This makes it useful for maintenance operations or when the air supply to a machine or piece of equipment needs to be shut off.

Manual, pneumatic, electro-pneumatic and assisted electro-pneumatic control versions are available. The last version must be used if the inlet pressure is outside the electro-pneumatic valve operating range, so for particularly low or high pressures.

The version with manual control can be locked and you can enter up to two padlocks on size 1 and up to three on size 2 when the valve is in the closed position. On the front and back there is a port (1/8" for size 1 and 1/4" size 2) that can be used with pressure gauges, pressure switches or as an additional air intake.



TECHNICAL DATA

	V3V SY1			V3V SY2			
	1/8"	1/4"	3/8"	3/8"	1/2"	3/4"	1"
Threaded port	1/8"	1/4"	3/8"	3/8"	1/2"	3/4"	1"
Threaded discharge port	1/8"			1/4"			
Type of control	Manual - pneumatic - Elpn - Elpn pilot-assisted			Manual - Pneumatic - Cnomo elpn - Cnomo elpn pilot-assisted			
Max inlet pressure for pneumatic and solenoid pilot-assisted versions	bar 15			bar 13			
	MPa 1.5			MPa 1.3			
	psi 217			psi 188			
Inlet pressure for solenoid version	bar 3 - 10			bar 3 - 10			
	MPa 0.3 - 1			MPa 0.3 - 1			
	psi 43 - 145			psi 43 - 145			
Pilot pressure for pneumatic and solenoid pilot-assisted versions	bar 3 - 10			bar 3 - 10			
	MPa 0.3 - 1			MPa 0.3 - 1			
	psi 43 - 145			psi 43 - 145			
Flow rate at 6.3 bar (0.63 MPa; 91 psi) ΔP 0.5 bar (0.05 MPa; 7 psi)	Nl/min 800	Nl/min 1000	Nl/min 1100	Nl/min 2800	Nl/min 3000	Nl/min 3000	Nl/min 3000
	scfm 28	scfm 35	scfm 39	scfm 99	scfm 106	scfm 106	scfm 106
Flow rate at 6.3 bar (0.63 MPa; 91 psi) ΔP 1 bar (0.1 MPa; 14 psi)	Nl/min 1100	Nl/min 1500	Nl/min 1600	Nl/min 3600	Nl/min 4000	Nl/min 4000	Nl/min 4000
	scfm 39	scfm 53	scfm 57	scfm 127	scfm 141.5	scfm 141.5	scfm 141.5
Exhaust flow rate at 6.3 bar (0.63 MPa; 91 psi)	Nl/min 500			Nl/min 2000			
	scfm 18			scfm 71			
Min/max temperature at 10 bar; 1 MPa; 145 psi	°C From -10 to +50			°C From -10 to +50			
Padlockable knob				Included			
Weight	g 197	g 192	g 183	g 476	g 449	g 445	g 433
Fluid	Compressed air or other inert gases						
Mounting position				In any position			
Additional air take-off, for pressure gauges or fittings	1/8", front and rear			1/4", front and rear			
Additional air take-off flow rate at 6.3 bar (0.63 MPa; 91 psi) ΔP 1 bar (0.1 MPa; 14 psi)	Nl/min 500			Nl/min 1500			
	scfm 18			scfm 53			
Wall fixing screws	No. 2 M4 screws			No. 2 M5 screws			
Bobbin capacity for electro-pneumatic version	W 12 VDC and 24 VDC = 2W			W 12 VDC and 24 VDC = 2W; 24 VAC, 110 VAC and 220 VAC = 3.5 VA			
	24 VAC, 110 VAC and 220 VAC = 3.5 VA			24 VDC = 4W; 24 VAC, 110 VAC, 220 VAC = 4 VA			
Manual control of electro-pneumatic versions	Bistable: horizontal = OFF, vertical = ON						

COMPONENTS

- ① Technopolymer knob
- ② Technopolymer hinge
- ③ Technopolymer body
- ④ NBR o-ring gasket
- ⑤ IN/OUT bushing made of OT58 nickel-plated brass or passivated aluminium for 3/4" - 1"
- ⑥ OT58 brass valve with NBR vulcanized gasket
- ⑦ Stainless steel valve spring
- ⑧ Technopolymer plug
- ⑨ OT58 brass threaded insert
- ⑩ Galvanised steel plate for knob locking (stainless steel for anti-corrosion version)
- ⑪ Stainless steel spring stem recovery
- ⑫ OT58 brass stem

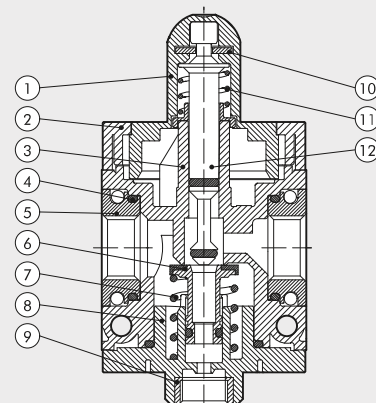

DIMENSIONS

MANUAL

SY1-SY2

PNEUMATIC

SY1-SY2

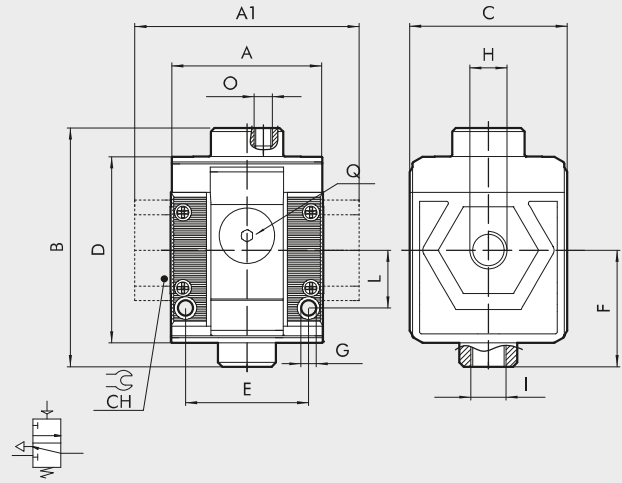
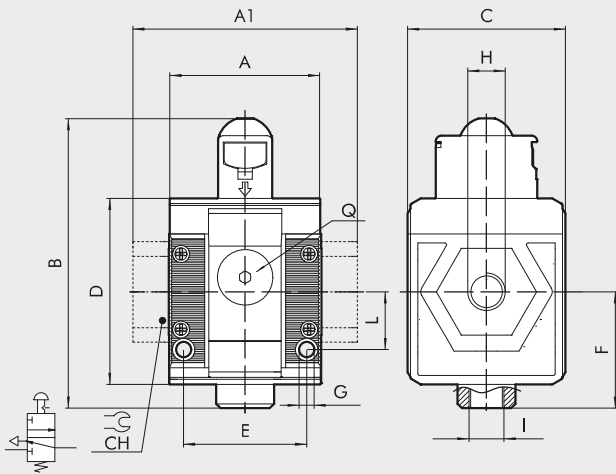

SOLENOID/SOLENOID PILOT-ASSISTED*

SY1

CNOMO SOLENOID / CNOMO SOLENOID PILOT-ASSISTED*

SY2

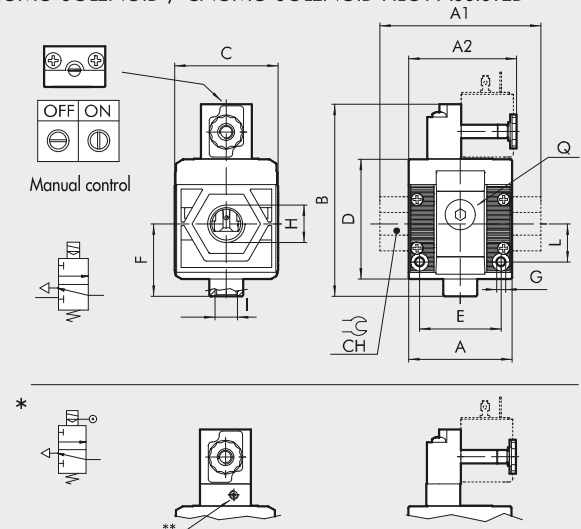
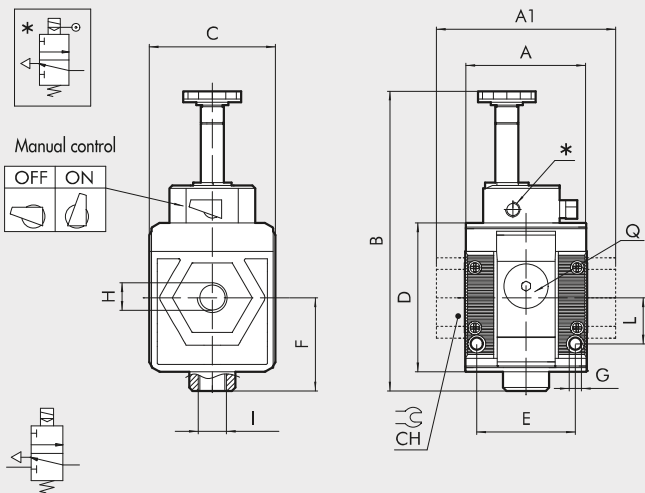

	MANUAL				PNEUMATIC				SOLENOID/SOLENOID PILOT-ASSISTED			CNOMO SOLENOID/CNOMO SOLENOID PILOT-ASSISTED												
	SIZE 1		SIZE 2		SIZE 1		SIZE 2		SIZE 1			SIZE 2												
H (threaded port)	1/8"	1/4"	3/8"	3/8"	1/2"	3/4"	1"	1/8"	1/4"	3/8"	3/8"	1/2"	3/4"	1"	1/8"	1/4"	3/8"	3/8"	1/2"	3/4"	1"			
A	-	42	-	-	61	-	42	-	-	61	-	-	42	-	-	-	-	-	-	61	-	-	95	95
A1	-	-	44	-	-	95	95	-	-	44	-	-	95	95	-	-	-	-	-	-	-	-	95	95
A2	-	-	-	-	-	-	-	-	-	-	-	-	-	-	-	-	-	-	-	-	-	-	65	-
B	80	-	-	109	-	-	-	66	-	-	94	-	-	104	-	-	-	-	-	-	-	-	-	113
Cnomo	-	-	-	-	-	-	-	-	-	-	-	-	-	-	-	-	-	-	-	-	-	-	-	126
Cnomo pilot ass.	-	-	-	-	-	-	-	-	-	-	-	-	-	-	-	-	-	-	-	-	-	-	-	61
C	44	-	-	61	-	-	-	44	-	-	61	-	-	44	-	-	-	-	-	-	-	-	-	61
CH	-	-	-	-	32	36	-	-	-	32	36	-	-	-	-	-	-	-	-	-	-	-	32	36
D	51.5	-	-	70.5	-	-	-	51.5	-	-	70.5	-	-	51.5	-	-	-	-	-	-	-	-	-	70.5
E	33.5	-	-	47.5	-	-	-	33.5	-	-	47.5	-	-	33.5	-	-	-	-	-	-	-	-	-	47.5
F	32.2	-	-	42.7	-	-	-	32.2	-	-	42.7	-	-	32.2	-	-	-	-	-	-	-	-	-	42.7
G	Hole for M4 screws		Hole for M5 screws		Hole for M4 screws		Hole for M5 screws		Hole for M4 screws			Hole for M5 screws												
I (exhaust)	1/8"	-	-	1/4"	-	-	1/8"	-	-	1/8"	-	-	1/4"	-	-	-	-	-	-	-	-	-	-	1/4"
L	16	-	-	22.5	-	-	16	-	-	22.5	-	-	16	-	-	-	-	-	-	-	-	-	-	22.5
O (pilot)	-	-	-	-	-	-	M5	-	-	1/8"	-	-	-	-	-	-	-	-	-	-	-	-	-	-
Q (no. 2 additional air takes-off)	1/8"	-	-	1/4"	-	-	1/8"	-	-	1/4"	-	-	1/8"	-	-	-	-	-	-	-	-	-	-	1/4"
** Pilot	-	-	-	-	-	-	-	-	-	-	-	-	-	M5	-	-	-	-	-	-	-	-	-	M5

KEY TO CODES

56	1	1	V	10	1
SYNTESI	SIZE	THREADED INPUT CONNECTION	ELEMENT	TYPE	THREADED OUTPUT CONNECTION
56 Syntesi 5X Syntesi anti-corrosion	1 Size 1 <hr/> 2 Size 2	0 Without bushing 1 1/8" port 2 1/4" port 3 3/8" port <hr/> 0 Without bushing 3 3/8" port 4 1/2" port 5 3/4" port 6 1" port	V Shut-off valve	10 Manual ● 20 Pneumatic ● 30 Solenoid pilot-assisted ● 70 Solenoid	0 Without bushing 1 1/8" port 2 1/4" port 3 3/8" port <hr/> 0 Without bushing 3 3/8" port 4 1/2" port 5 3/4" port 6 1" port

● Not available in the anti-corrosion version.

PURCHASE ORDER CODES HAVING A MORE FREQUENT USE

N.B. Besides the below mentioned codes, you can order elements composed at your will according to the key to codes.

Code	Description	Code	Description	NOTE
Syntesi® SY1 SHUT-OFF VALVE				NOTE Anti-corrosion version 5X ----- Example 5X11V101 V3V SY1 1/8 anti-corrosion
5610V100	V3V SY1 manual without bushings	5620V100	V3V SY2 manual without bushings	
5611V101	V3V SY1 1/8 manual	5623V103	V3V SY2 3/8 manual	
5612V102	V3V SY1 1/4 manual	5624V104	V3V SY2 1/2 manual	
5613V103	V3V SY1 3/8 manual	5625V105	V3V SY2 3/4 manual	
		5626V106	V3V SY2 1 manual	
5610V200	V3V SY1 pneumatic without bushings	5620V200	V3V SY2 pneumatic without bushings	
5611V201	V3V SY1 1/8 pneumatic	5623V203	V3V SY2 3/8 pneumatic	
5612V202	V3V SY1 1/4 pneumatic	5624V204	V3V SY2 1/2 pneumatic	
5613V203	V3V SY1 3/8 pneumatic	5625V205	V3V SY2 3/4 pneumatic	
		5626V206	V3V SY2 1 pneumatic	
5610V300	V3V SY1 elpn pilot-assisted without bushings	5620V300	V3V SY2 elpn pilot-assisted Cnomo without bushings	
5611V301	V3V SY1 1/8 elpn pilot-assisted	5623V303	V3V SY2 3/8 elpn pilot-assisted Cnomo	
5612V302	V3V SY1 1/4 elpn pilot-assisted	5624V304	V3V SY2 1/2 elpn pilot-assisted Cnomo	
5613V303	V3V SY1 3/8 elpn pilot-assisted	5625V305	V3V SY2 3/4 elpn pilot-assisted Cnomo	
		5626V306	V3V SY2 1 elpn pilot-assisted Cnomo	
5610V700	V3V SY1 elpn without bushings	5620V700	V3V SY2 elpn without bushings	
5611V701	V3V SY1 1/8 elpn	5623V703	V3V SY2 3/8 elpn	
5612V702	V3V SY1 1/4 elpn	5624V704	V3V SY2 1/2 elpn	
5613V703	V3V SY1 3/8 elpn	5625V705	V3V SY2 3/4 elpn	
		5626V706	V3V SY2 1 elpn	

NOTES