

1

2

3

4

5

6

RevNo	Revision note	Date	Signature	Checked
-------	---------------	------	-----------	---------

A

B

C

D

M5x0.7 Threaded hole

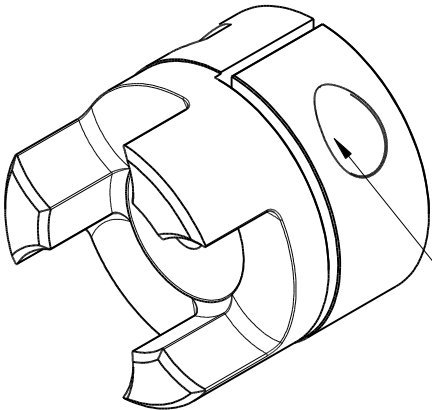
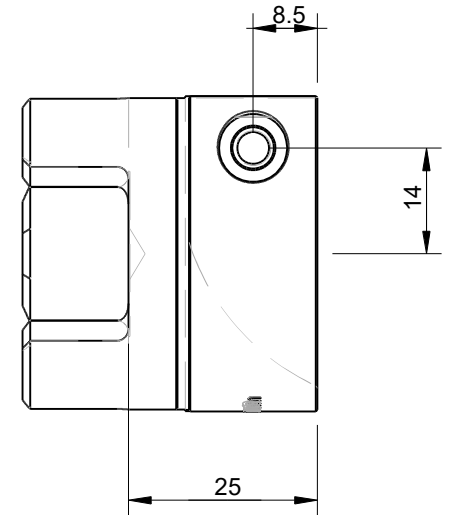
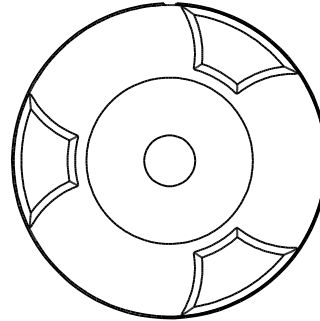
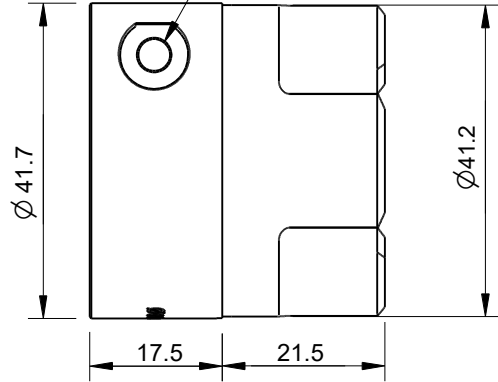

Pocket for bolt M5x16 DIN 912

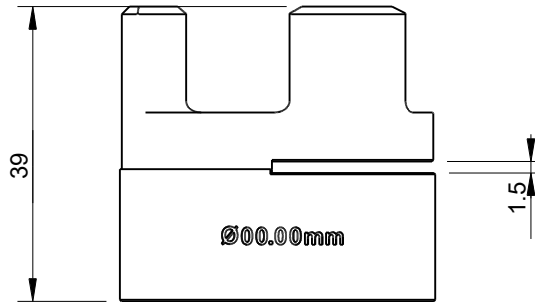

Units	mm
Tolerances	$\pm 0.1\text{mm}$ unless otherwise specified
Material	Alu 6082
Tumbling	Yes
Surface finish	None

Itemref	Quantity	Title/Name, designation, material, dimension etc	Article No./Reference
Drawn by Cas Jansen	Checked by Kevin Damen	Approved by - date 31-7-2020	Date 30-7-2020
Scale 1:1		File name	

5123

www.damencnc.com

5123 HUB ShaftCoupler DCNC-D40-L65-B0.00mm (only centered)	Edition	Sheet 1 OF 11
--	---------	------------------

1

2

3

4

5

6