

RevNo	Revision note	Date	Signature	Checked
-------	---------------	------	-----------	---------

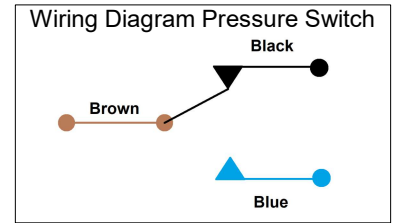
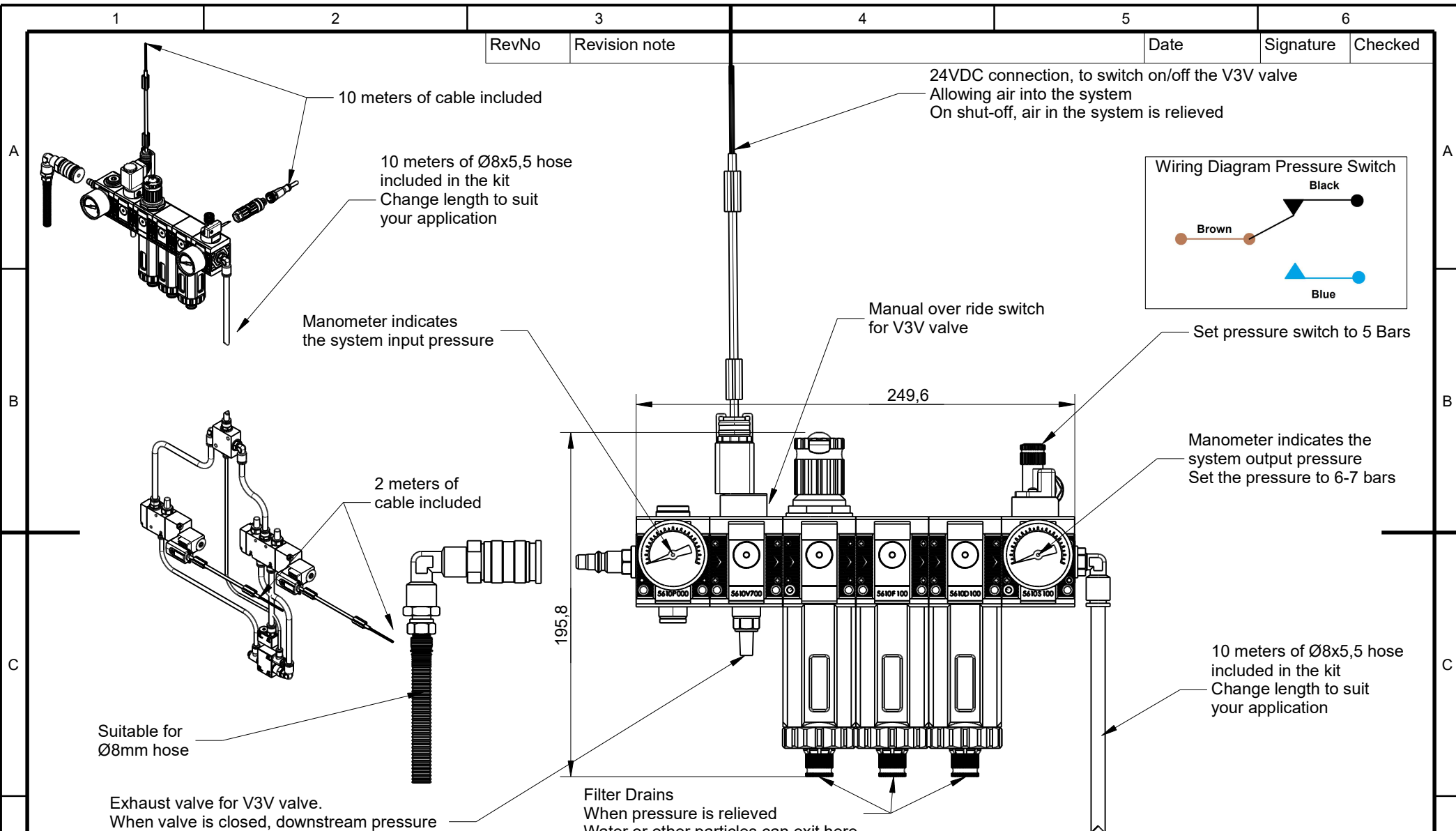

Itemref	Quantity	Title/Name, designation, material, dimension etc	Article No./Reference
Drawn by Kevin Damen	Checked by M.Vork	Approved by - date 12-12-2022	File name Date 12-12-2022 Scale 1:1

Units	mm
Tolerances	+/- 0.2mm

**5290**

[www.damencnc.com](http://www.damencnc.com)

5290 DIY Pneumatic Package for TeknoMotor ATC41	Edition	Sheet 1 OF 2
--	---------	-----------------