

|       |               |   |      |           |         |
|-------|---------------|---|------|-----------|---------|
| 1     | 2             | 3 | 4    | 5         | 6       |
| RevNo | Revision note |   | Date | Signature | Checked |

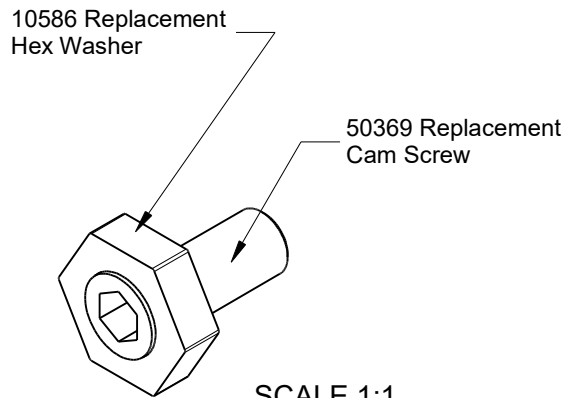
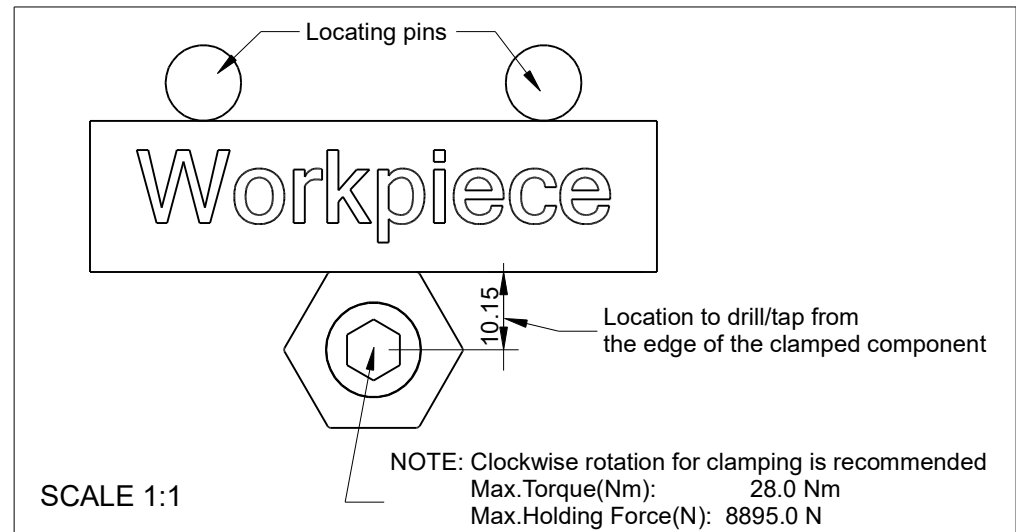
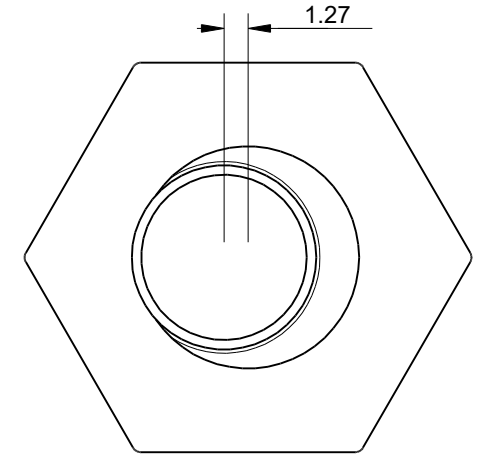
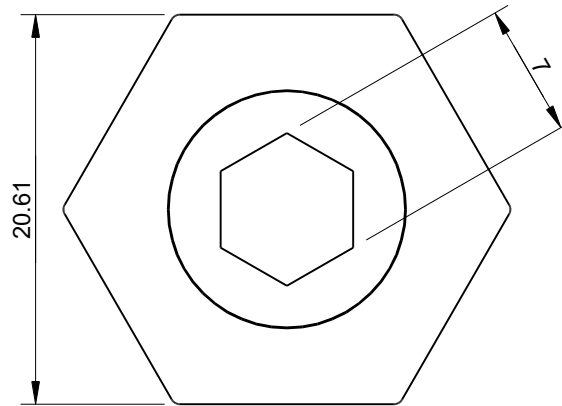
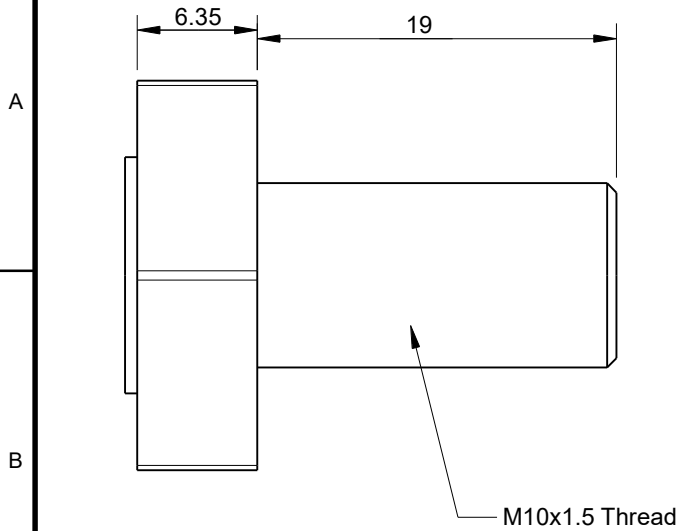

|                |                                    |
|----------------|------------------------------------|
| Units          | mm                                 |
| Tolerances     | ± 0.1mm unless otherwise specified |
| Material       | Steel (bolt) & brass (hex)         |
| Tumbling       | No                                 |
| Surface finish | None                               |

|                        |                           |  |                       |                    |                |
|------------------------|---------------------------|--|-----------------------|--------------------|----------------|
| Itemref                | Quantity                  | Title/Name, designation, material, dimension etc | Article No./Reference |                    |                |
| Drawn by<br>Cas Jansen | Checked by<br>Kevin Damen | Approved by - date<br>24-12-2020                 | File name             | Date<br>24-12-2020 | Scale<br>2.5:1 |

**5387**

[www.damencnc.com](http://www.damencnc.com)

|      |  |         |                 |
|------|--|---------|-----------------|
| 5387 | Fixture Clamp M10 ,<br>Eccentric CAM mechanism (50210) | Edition | Sheet<br>1 OF 1 |
|------|--|---------|-----------------|