

Power Connector

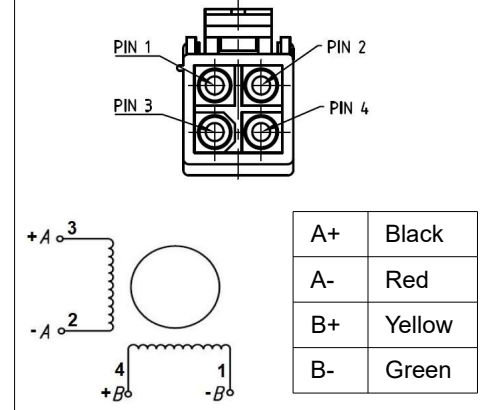

SCALE 1:5

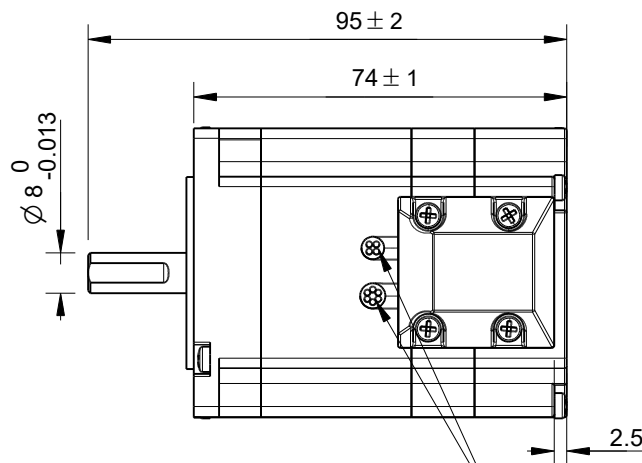

Encoder Connector

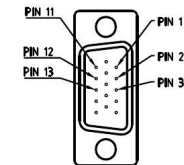

PIN	1	2	3	11	12	13
Color	BLK	RED	WHT	YEL	GRN	BLU
Define	A+	VCC	GND	B+	B-	A-

Phase	2 Phase	
Step angle	1.8 ± 5%	°/step
Rotor Inertia	0.30x10 ⁻⁴	kgm ²
Rated Voltage	1.68	VDC
Rated Current	4.0	Amps/Phase
Resistance	0.42 ± 10%	Ω/Phase
Inductance	1.6 ± 20%	mH/Phase
Insulation resistance	100	MΩ Min
Holding Torque	1.3	Nm Min
Detent Torque	0.02	Nm Max
Encoder Resolution	1000	CPR
Radial play	Max 0.02mm (Load 450g)	
Axial play	Max 0.08mm (Load 900g)	
Insulation Class	B	
Mass	0.9	Kg
Units	mm	
Tolerances	± 0.1mm unless otherwise specified	

Itemref	Quantity	Title/Name, designation, material, dimension etc			Article No./Reference	
Drawn by Cas Jansen	Checked by	Approved by - date	File name	Date 14-10-2022	Scale 1:1.5	

6022

www.damencnc.com