

1

2

3

4

5

6

RevNo

Revision note

Date

Signature

Checked

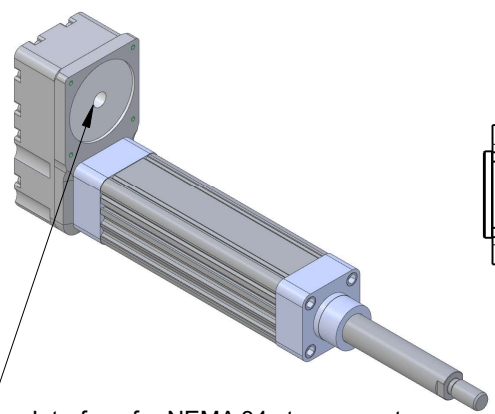
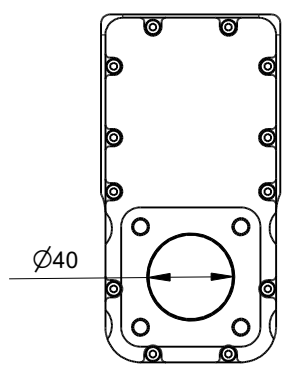
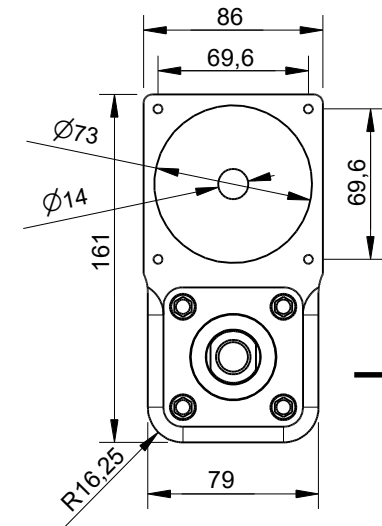
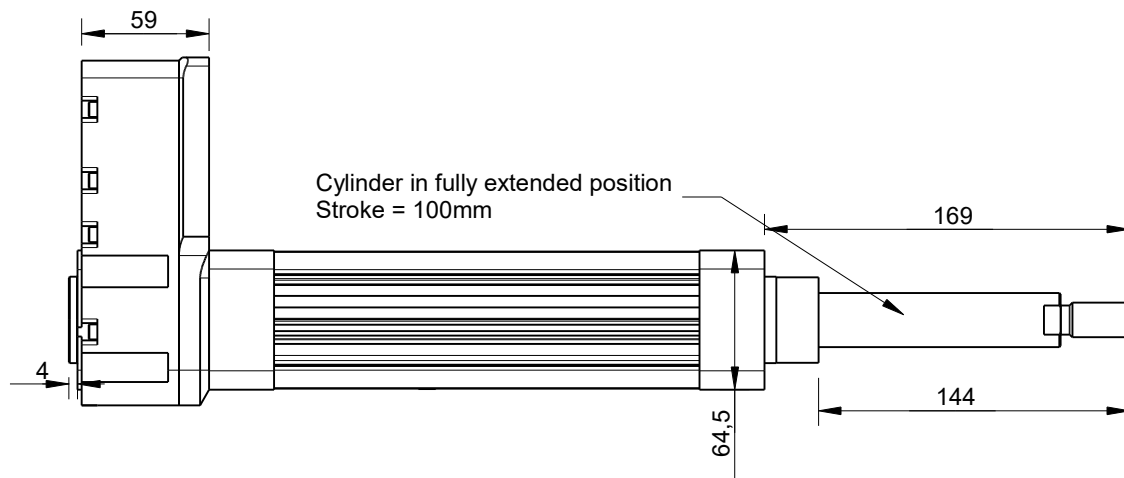
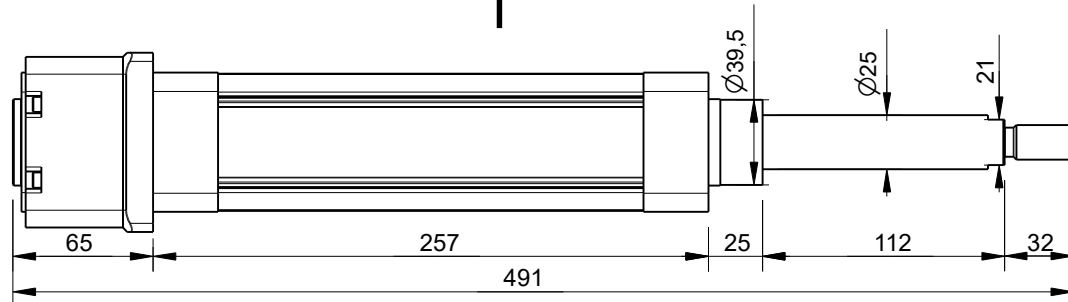

Interface for NEMA 34 stepper motors
 86x86mm frame size
 73mm center ring
 14mm shaft diameter
 4 x m5 thread

Itemref	Quantity	Title/Name, designation, material, dimension etc			Article No./Reference	
Drawn by Kevin Damen	Checked by	Approved by - date	File name	Date 6-2-2024	Scale 1:1	

6486

www.damencnc.com

6486 Electronic Cylinder ISO15552-B50-S100-P5-Geared-Anti Rotation-IP55 IP65	Edition	Sheet 1 OF 1
--	---------	-----------------

Unit: mm Tolerances: +/-0.1mm

1

2

3

4

5

6