

1

2

3

4

5

6

RevNo

Revision note

Date

Signature

Checked

A

A

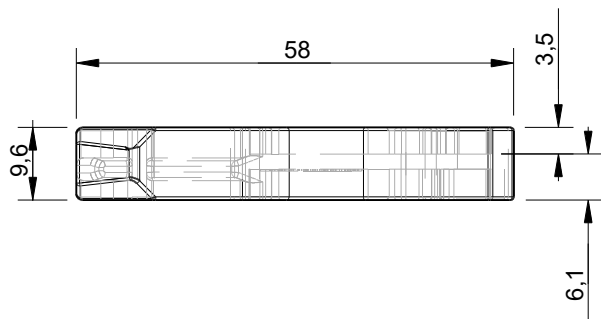
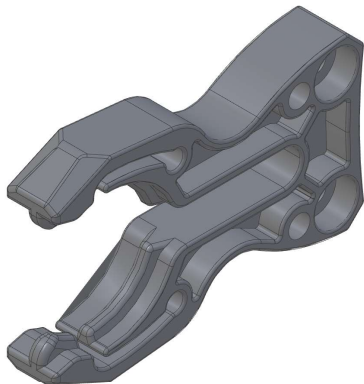

Suitable for $\varnothing 4$ dowel pins
 To get a more exact position on the machines toolrack
Advised: Ream the hole before installation with $\varnothing 4H7$ Reamer

B

B

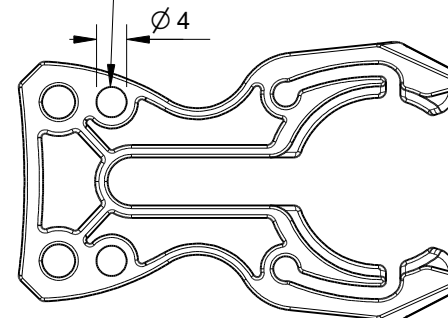
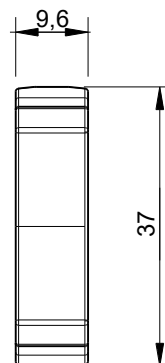
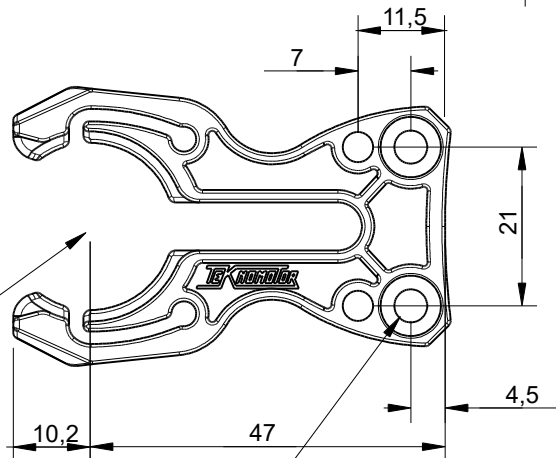

Suitable for HSK25E Toolholders

Suitable for DIN912 M4 Bolts
 2 x $\varnothing 8.0 \nabla 5$
 2 x $\varnothing 4.4 \nabla$ THRU

Warning: The dimensions could alter slightly, due to the injection molding manufacturing process

D

D

Units	mm
Tolerances	$\pm 0.1\text{mm}$ unless otherwise specified
Material	PA 6/Nylon 6
Colour	Medium Grey

Itemref	Quantity	Title/Name, designation, material, dimension etc	Article No./Reference		
Drawn by Kevin Damen	Checked by	Approved by - date	File name	Date 21-2-2024	Scale 1:1

6600

www.damencnc.com

6600 TeknoMotor Toolholder Fork HSK 25 E	Edition	Sheet 1 OF 1
--	---------	-----------------

1

2

3

4

5

6