

1

2

3

4

5

6

RevNo Revision note

Date

Signature

Checked

A

A

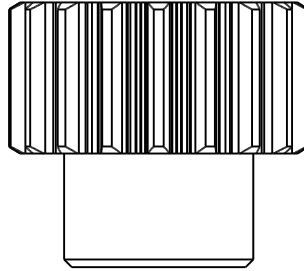
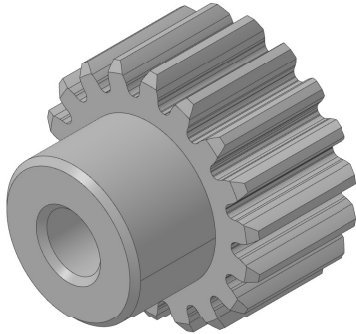

B

B

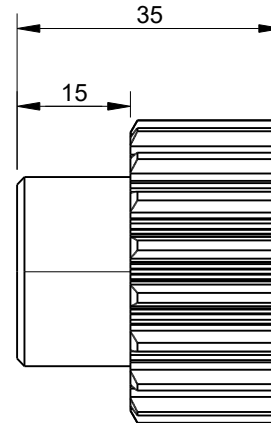
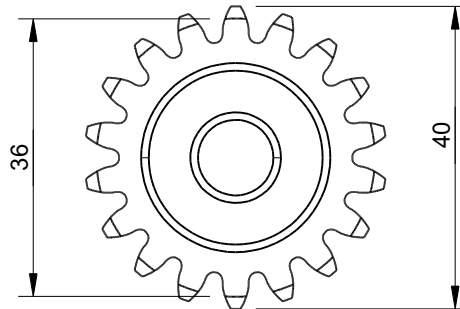
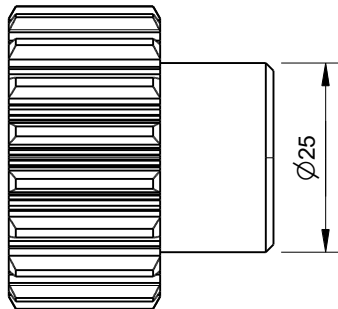

C

C

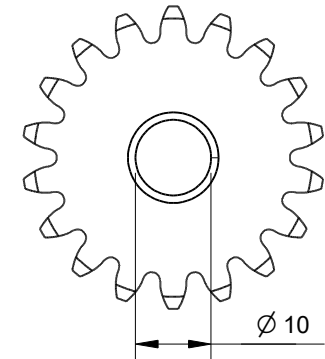

D

D

Number of Teeth (Z)	18
Module	2
Pressure Angle	20°
Outside \varnothing	40
Pitch \varnothing	36
Root \varnothing	29
Bore \varnothing	10
Material	Steel C45
Units	mm
Tolerances	+/- 0.1mm unless otherwise specified

Itemref	Quantity	Title/Name, designation, material, dimension etc			Article No./Reference	
Drawn by Kevin Damen	Checked by	Approved by - date	File name	Date 1-7-2024	Scale 1:1	

6883

www.damencnc.com

6883 Module 2 Gear, with 18 teeth

Edition	Sheet
	1 OF 1

1

2

3

4

5

6