

1

2

3

4

5

6

RevNo	Revision note		Date	Signature	Checked
-------	---------------	--	------	-----------	---------

A

A

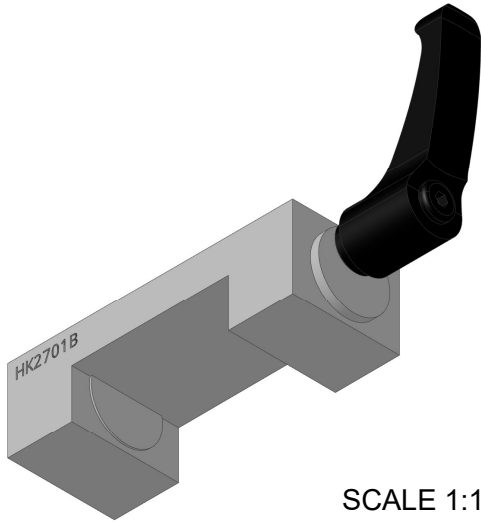

SCALE 1:1,5

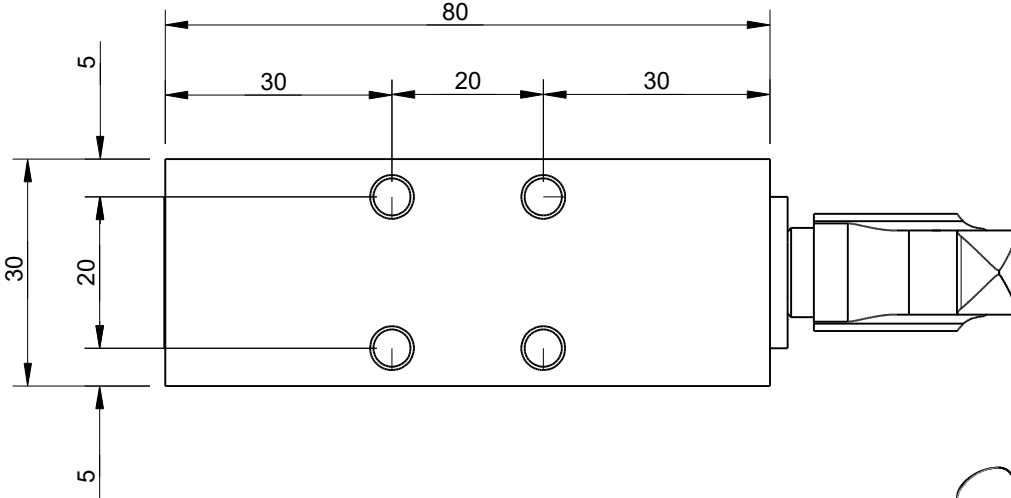

B

B

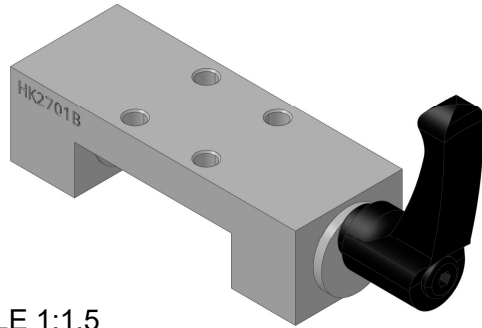

SCALE 1:1,5

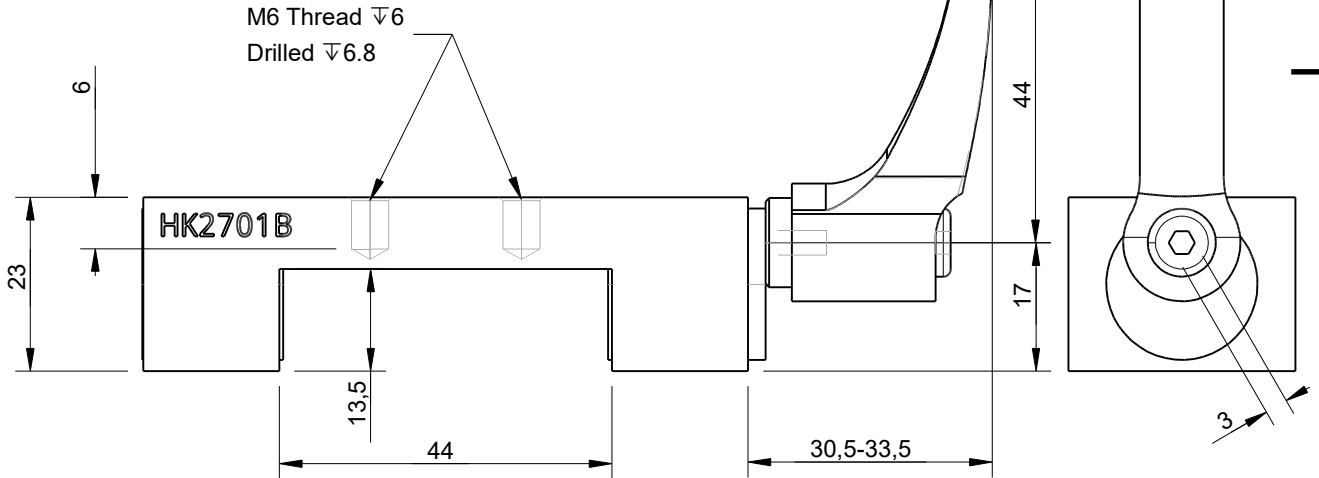

C

C

Technical Data	
Holding Force	1200 N
Tightening torque	4 Nm
Installation direction	from above
Max Clamping Length	30 mm
Weight	0.3 kg
Units	mm
Tolerances	+/-0.1 mm

D

D

Itemref	Quantity	Title/Name, designation, material, dimension etc			Article No./Reference	
Drawn by Kevin Damen	Checked by	Approved by - date	File name	Date 11-8-2024	Scale 1:1	

6912

www.damencnc.com

6912 HK2701B Wide - Manual Clamping Element		Edition	Sheet 1 OF 1
--	--	---------	-----------------

1

2

3

4

5

6