

1

2

3

4

5

6

RevNo	Revision note		Date	Signature	Checked
-------	---------------	--	------	-----------	---------

A

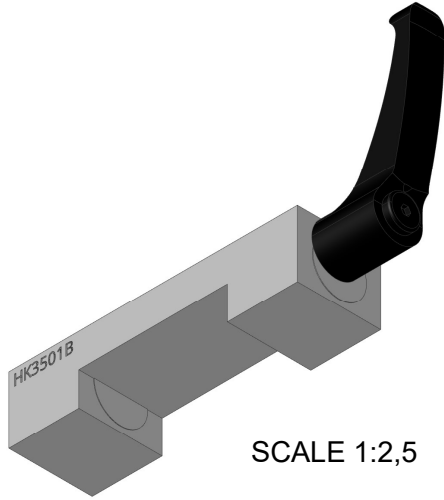

SCALE 1:2,5

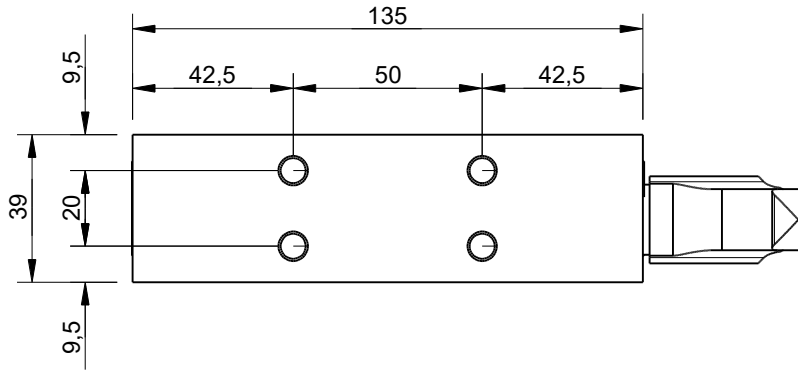

B

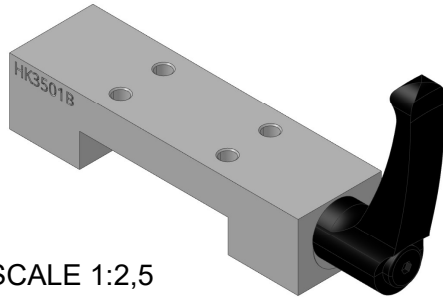

SCALE 1:2,5

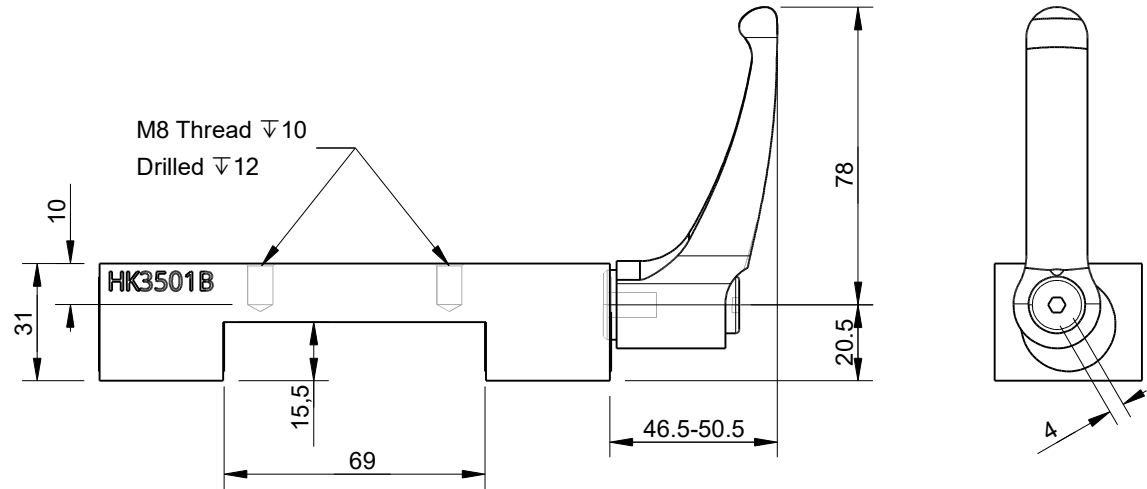

C

Technical Data	
Holding Force	2000 N
Tightening torque	15 Nm
Installation direction	from above
Max Clamping Length	39 mm
Weight	1.1 kg
Units	mm
Tolerances	+/-0.1 mm

D

Itemref	Quantity	Title/Name, designation, material, dimension etc			Article No./Reference	
Drawn by Kevin Damen		Checked by	Approved by - date	File name	Date 9-8-2024	Scale 1:2

6913

www.damencnc.com

6913 HK3501B Wide - Manual Clamping Element		Edition	Sheet 1 OF 1
--	--	---------	-----------------

1

2

3

4

5

6