

### 3.4 WE/QW series

#### 3.4.1 Properties of the linear guideway, series WE and QW

The HIWIN linear guideways of the WE series are based on proven HIWIN technology. Their large rail width and low installation height permit a compact design and high torque loading capacity.

The models of the QW series with SynchMotion™ technology offer all the advantages of the standard series WE. Controlled movement of the balls at a defined distance also results in improved synchronous performance, higher reliable travel speeds, extended lubrication intervals and less running noise. Since the installation dimensions of the QW blocks are identical to those of the WE blocks, they are also fitted on the WER standard rail and can therefore be interchanged with ease. For more information, refer to [Page 24](#).

#### 3.4.2 Design of the WE/QW series

- 4-row recirculation ball bearing guide
- 45° contact angle
- Ball retainers prevent the balls from falling out when the block is removed
- Low installation height
- Wide linear guideway for high torque loading capacity
- Large mounting surface on block
- SynchMotion™ technology (QW series)

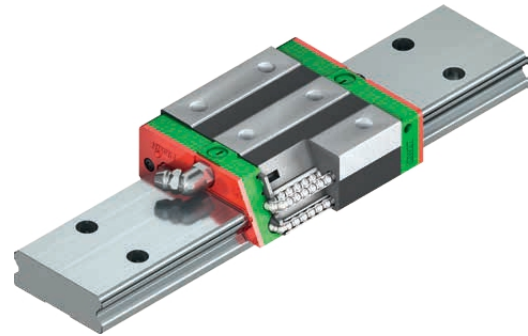
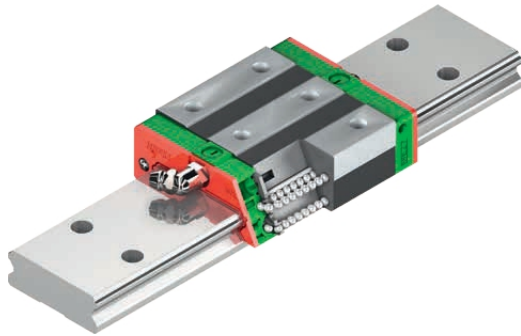

#### Design of the WE series

##### Advantages:

- Compact and low-cost design thanks to high torque loading capacity
- High efficiency thanks to low friction losses

#### Design of the QW series

##### Additional advantages of QW series:

- Improved synchronous performance
- Optimized for higher travel speeds
- Extended lubrication intervals
- Less running noise
- Higher dynamic load capacities

50% wider than standard series

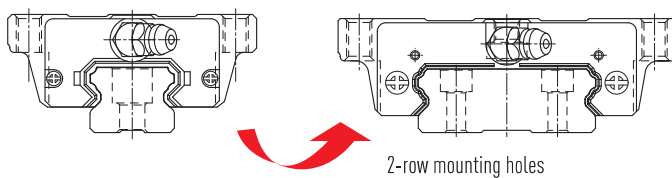

- The block's large mounting surface supports the transfer of higher torques
- The 45° arrangement of ball tracks permits high loading from all directions

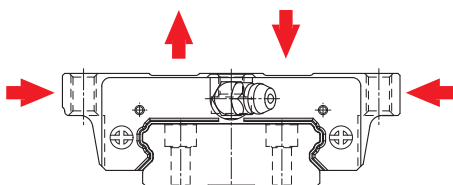

# Linear guideways

## WE/QW series

### 3.4.3 Order codes for the WE/QW series

For WE/QW linear guideways, a distinction is made between fully assembled and unmounted models. The dimensions of both models are the same. The main difference is that the block and rail in the unmounted models can be freely interchanged. Block and rail can therefore be ordered separately and fitted by the customer. Their accuracy extends to class P.

#### Order code for linear guideway (fully assembled)

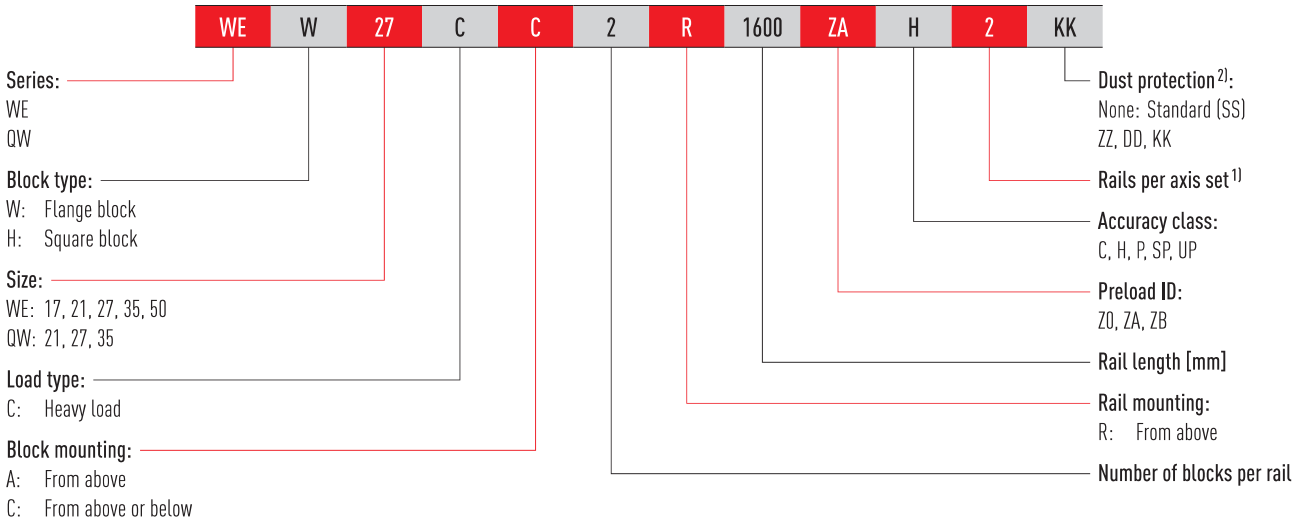

#### Order code for block (unmounted)

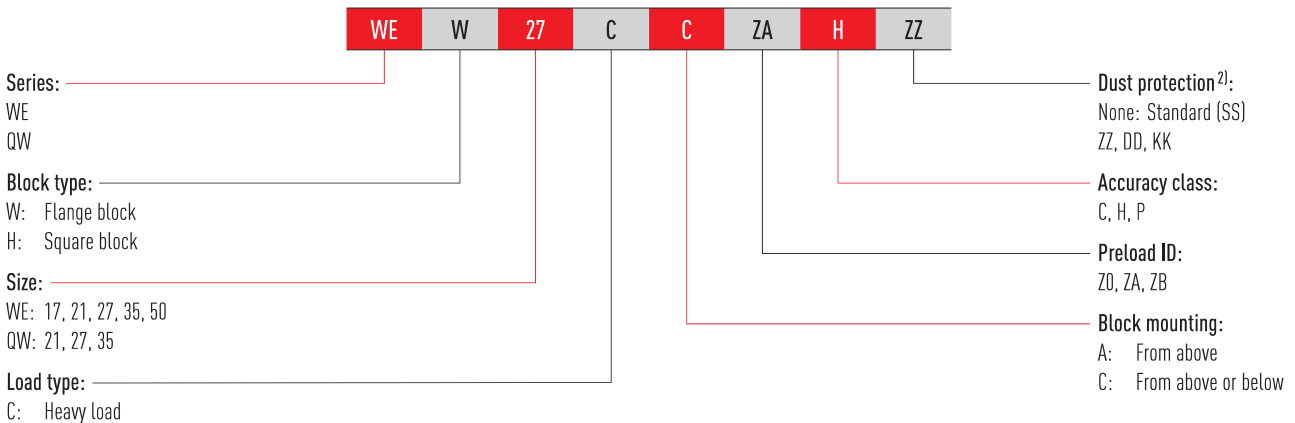

#### Order code for rail (unmounted)

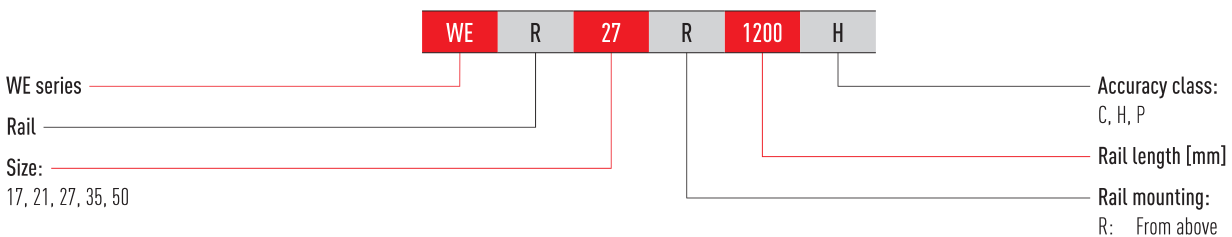

Note:

<sup>1)</sup> The figure 2 is also a quantity, i.e. one item of the above-mentioned article consists of a pair of rails. No number is specified for individual rails.

By default multi-part rails are delivered with staggered butt joints.

<sup>2)</sup> You will find an overview of the individual sealing systems on [Page 22](#)

### 3.4.4 Block types

HIWIN provides square and flange blocks for its linear guideways. Given their low height and larger mounting surface, flange blocks are better suited for large loads.

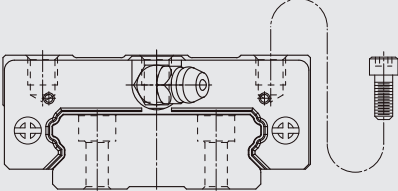
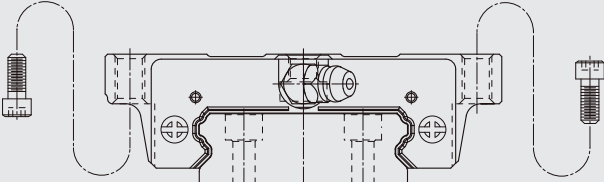
Type	Series/ Size	Structure	Height [mm]	Rail length [mm]	Typical application
Square type	WEH-CA QWH-CA		17 – 50	100 – 4.000	<ul style="list-style-type: none"> <li>○ Automation</li> <li>○ Handling industry</li> <li>○ Measuring and test technology</li> <li>○ Semiconductor industry</li> <li>○ Injection moulding machines</li> <li>○ Linear axes</li> </ul>
Flange type	WEW-CC QWW-CC				

### 3.4.5 Preload

#### Definition

Every rail type can be preloaded based on the size of the balls. The curve shows that the rigidity doubles at higher preload. The WE/QW series offers three standard preload classes for various applications and conditions.

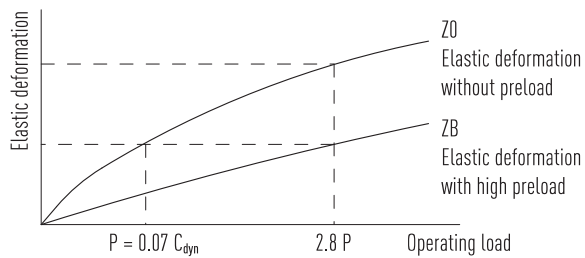

#### Preload ID

ID	Preload		Application	Sample applications
Z0	Light preload	$0 - 0.02 C_{dyn}$	Constant load direction, low impact, low accuracy needed	<ul style="list-style-type: none"> <li>○ Transport technology</li> <li>○ Automatic packaging machines</li> <li>○ X-Y axis in industrial machines</li> <li>○ Welding machines</li> </ul>
ZA	Medium preload	$0.03 - 0.05 C_{dyn}$	High accuracy needed	<ul style="list-style-type: none"> <li>○ Machining centres</li> <li>○ Z axes for industrial machines</li> <li>○ Eroding machines</li> <li>○ NC lathes</li> <li>○ Precision X-Y tables</li> <li>○ Measuring technology</li> </ul>
ZB	High preload	$0.06 - 0.08 C_{dyn}$	High rigidity needed, vibration and impact	<ul style="list-style-type: none"> <li>○ Machining centres</li> <li>○ Grinding machines</li> <li>○ NC lathes</li> <li>○ Horizontal and vertical milling machines</li> <li>○ Z axis of machine tools</li> <li>○ High-performance cutting machines</li> </ul>

# Linear guideways

## WE/QW series

### 3.4.6 Load ratings and torques

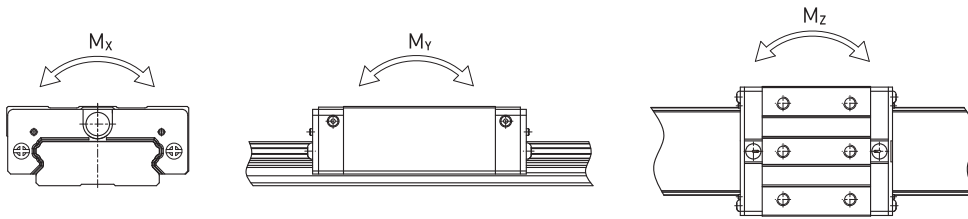

Table 3.60 Load ratings and torques for series WE/QW

Series/ size	Dynamic load rating $C_{dyn}$ [N] <sup>1)</sup>	Static load rating $C_0$ [N]	Dynamic moment [Nm]			Static moment [Nm]		
			$M_x$	$M_y$	$M_z$	$M_{0x}$	$M_{0y}$	$M_{0z}$
WE_17C	5,230	9,640	82	34	34	150	62	62
WE_21C	7,210	13,700	122	53	53	230	100	100
QW_21C	9,000	12,100	156	67	67	210	90	90
WE_27C	12,400	21,600	242	98	98	420	170	170
QW_27C	16,000	22,200	303	144	144	420	200	200
WE_35C	29,800	49,400	893	405	405	1,480	670	670
WE_35C	36,800	49,200	1,129	486	486	1,510	650	650
WE_50C	61,520	97,000	2,556	1,244	1,244	4,030	1,960	1,960

<sup>1)</sup> Dynamic load rating for travel distance of 50,000 m

### 3.4.7 Rigidity

Rigidity depends on preload. Formula F 3.10 can be used to determine deformation depending on rigidity.

#### F 3.10

$$\delta = \frac{P}{k}$$

$\delta$  Deformation [ $\mu\text{m}$ ]  
 $P$  Operating load [N]  
 $k$  Rigidity [N/ $\mu\text{m}$ ]

Table 3.61 Radial rigidity for series WE/QW

Load class	Series/ size	Rigidity depending on preload		
		Z0	ZA	ZB
Heavy load	WE_17C	128	166	189
	WE_21C	154	199	228
	QW_21C	140	176	200
	WE_27C	187	242	276
	QW_27C	183	229	260
	WE_35C	281	364	416
	QW_35C	277	348	395
	WE_50C	428	554	633

Unit: N/ $\mu\text{m}$

### 3.4.8 Dimensions of the WE/QW blocks

#### 3.4.8.1 WEH/QWH

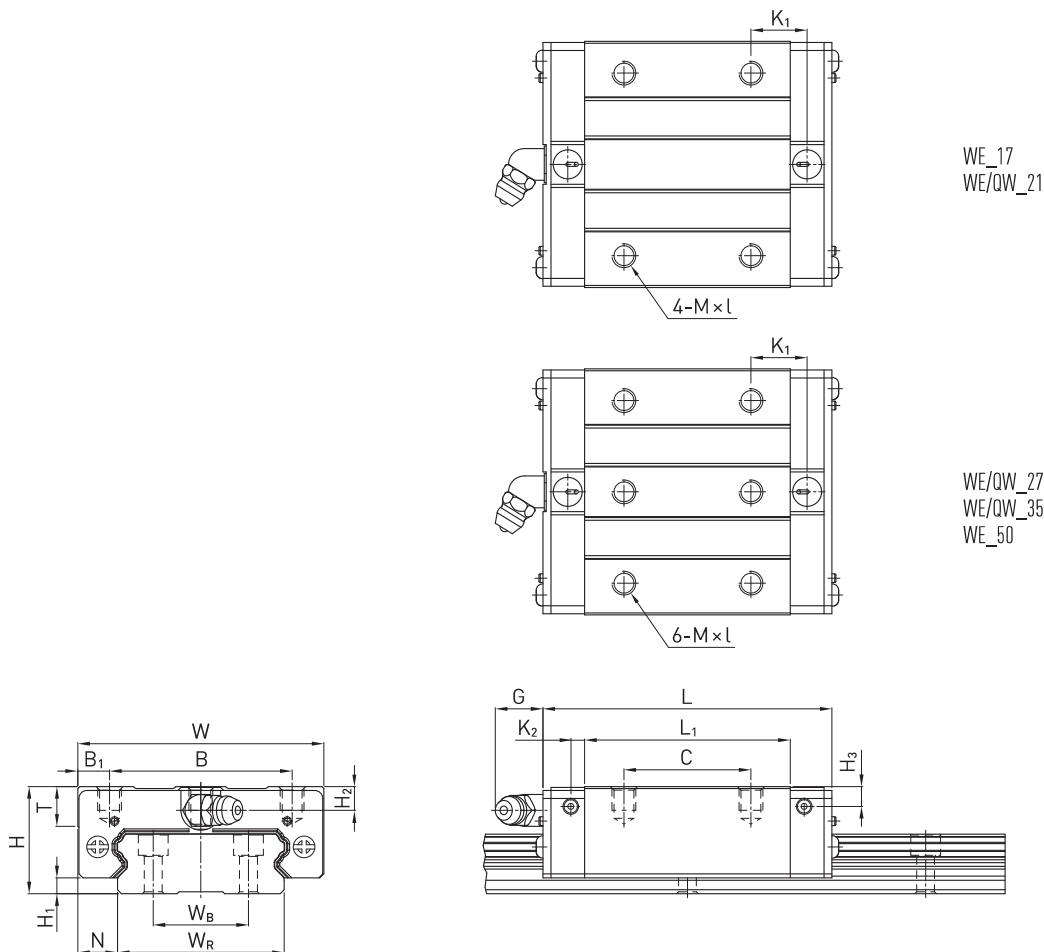

WE\_17  
WE/QW\_21

WE/QW\_27  
WE/QW\_35  
WE\_50

Table 3.62 Dimensions of the block

Series/ size	Installation dimensions [mm]			Dimensions of the block [mm]													Load ratings [N]		Weight [kg]
	H	H <sub>1</sub>	N	W	B	B <sub>1</sub>	C	L <sub>1</sub>	L	K <sub>1</sub>	K <sub>2</sub>	G	M × l	T	H <sub>2</sub>	H <sub>3</sub>	C <sub>dyn</sub>	C <sub>0</sub>	
WEH17CA	17	2.5	8.5	50	29	10.5	15	35.0	50.6	—	3.10	4.9	M4 × 5	6.0	4.0	3.0	5,230	9,640	0.12
WEH21CA	21	3.0	8.5	54	31	11.5	19	41.7	59.0	14.68	3.65	12.0	M5 × 6	8.0	4.5	4.2	7,210	13,700	0.20
QWH21CA	21	3.0	8.5	54	31	11.5	19	41.7	59.0	14.68	3.65	12.0	M5 × 6	8.0	4.5	4.2	9,000	12,100	0.20
WEH27CA	27	4.0	10.0	62	46	8.0	32	51.8	72.8	14.15	3.50	12.0	M6 × 6	10.0	6.0	5.0	12,400	21,600	0.35
QWH27CA	27	4.0	10.0	62	46	8.0	32	56.6	73.2	15.45	3.15	12.0	M6 × 6	10.0	6.0	5.0	16,000	22,200	0.35
WEH35CA	35	4.0	15.5	100	76	12.0	50	77.6	102.6	18.35	5.25	12.0	M8 × 8	13.0	8.0	6.5	29,800	49,400	1.10
QWH35CA	35	4.0	15.5	100	76	12.0	50	73.0	107.0	21.5	5.50	12.0	M8 × 8	13.0	8.0	6.5	36,800	49,200	1.10
WEH50CA	50	7.5	20.0	130	100	15.0	65	112.0	140.0	28.05	6.00	12.9	M10 × 15	19.5	12.0	10.5	61,520	97,000	3.16

For dimensions of rail, see [Page 83](#), for standard and optional lubrication adapter, see [Page 126](#).

# Linear guideways

WE/QW series

## 3.4.8.2 WEW/QWW

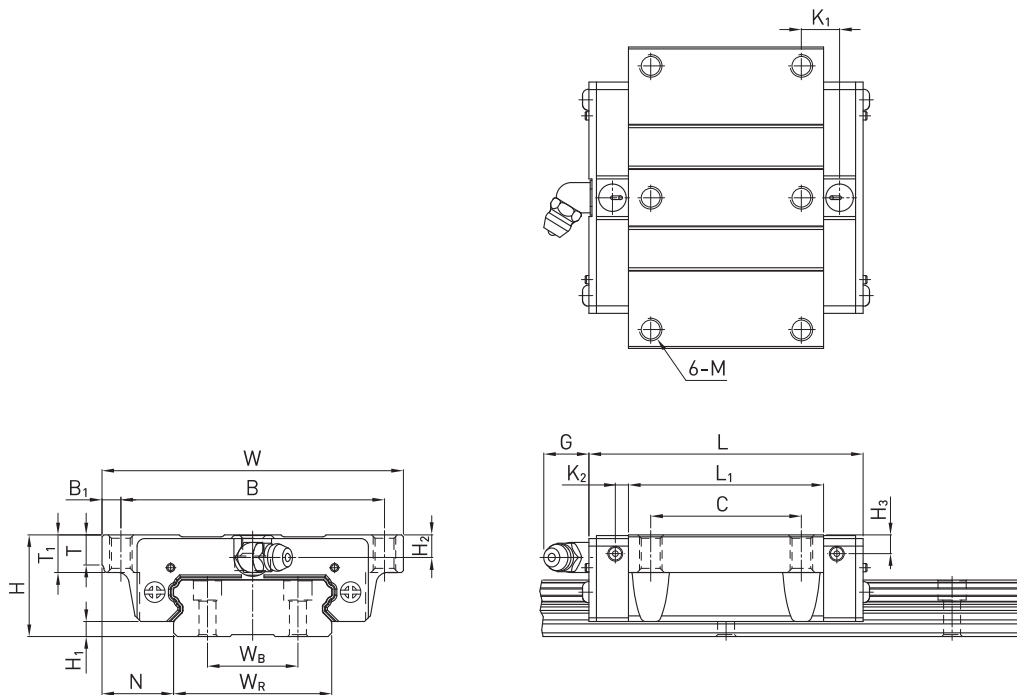

Table 3.63 Dimensions of the block

Series/ size	Installation dimensions [mm]			Dimensions of the block [mm]														Load ratings [N]		Weight [kg]
	H	H <sub>1</sub>	N	W	B	B <sub>1</sub>	C	L <sub>1</sub>	L	K <sub>1</sub>	K <sub>2</sub>	G	M	T	T <sub>1</sub>	H <sub>2</sub>	H <sub>3</sub>	C <sub>dyn</sub>	C <sub>0</sub>	
WEW17CC	17	2.5	13.5	60	53	3.5	26	35.0	50.6	—	3.10	4.9	M4	5.3	6	4.0	3.0	5,230	9,640	0.13
WEW21CC	21	3.0	15.5	68	60	4.0	29	41.7	59.0	9.68	3.65	12.0	M5	7.3	8	4.5	4.2	7,210	13,700	0.23
QWW21CC	21	3.0	15.5	68	60	4.0	29	41.7	59.0	9.68	3.65	12.0	M5	7.3	8	4.5	4.2	9,000	12,100	0.23
WEW27CC	27	4.0	19.0	80	70	5.0	40	51.8	72.8	10.15	3.50	12.0	M6	8.0	10	6.0	5.0	12,400	21,600	0.43
QWW27CC	27	4.0	19.0	80	70	5.0	40	56.6	73.2	15.45	3.15	12.0	M6	8.0	10	6.0	5.0	16,000	22,200	0.43
WEW35CC	35	4.0	25.5	120	107	6.5	60	77.6	102.6	13.35	5.25	12.0	M8	11.2	14	8.0	6.5	29,800	49,400	1.26
QWW35CC	35	4.0	25.5	120	107	6.5	60	83.0	107.0	21.50	5.50	12.0	M8	11.2	14	8.0	6.5	36,800	49,200	1.26
WEW50CC	50	7.5	36.0	162	144	9.0	80	112.0	140.0	20.55	6.00	12.9	M10	14.0	18	12.0	10.5	61,520	97,000	3.71

For dimensions of rail, see [Page 83](#), for standard and optional lubrication adapter, see [Page 126](#).

### 3.4.9 Dimensions of the WE rail

#### 3.4.9.1 Dimensions of WER\_R

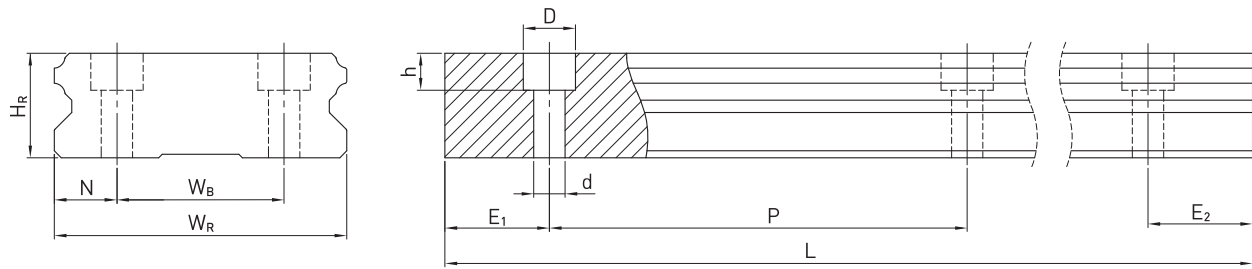

Table 3.64 Dimensions of rail WER\_R

Series/ size	Assembly screw for rail [mm]	Dimensions of the rail [mm]							Max. length [mm]	Max. length $E_1 = E_2$ [mm]	$E_{1/2}$ min [mm]	$E_{1/2}$ max [mm]	Weight [kg/m]
		$W_R$	$W_B$	$H_R$	$D$	$h$	$d$	$P$					
WER17R	M4 × 12	33	18	9.3	7.5	5.3	4.5	40	4,000	3,960	6	34	2.2
WER21R	M4 × 12	37	22	11.0	7.5	5.3	4.5	50	4,000	3,950	6	44	3.0
WER27R	M4 × 16	42	24	15.0	7.5	5.3	4.5	60	4,000	3,900	6	54	4.7
WER35R	M6 × 20	69	40	19.0	11.0	9.0	7.0	80	4,000	3,920	8	72	9.7
WER50R	M8 × 25	90	60	24.0	14.0	12.0	9.0	80	4,000	3,920	9	71	14.6

Note:

1. The tolerance for  $E$  is  $+0.5$  to  $-1$  mm for standard rails and  $0$  to  $-0.3$  mm for joints.
2. If the  $E_{1/2}$  dimensions are not indicated, the maximum possible number of mounting holes will be determined under consideration of  $E_{1/2}$  min.
3. The rails are shortened to the required length. If the  $E_{1/2}$  dimensions are not indicated, these will be carried out symmetrically.

#### 3.4.9.2 Calculating the length of rails

HIWIN offers rails in customized lengths. To prevent the risk of the end of the rail becoming unstable, the value  $E$  must not exceed half of the distance between the mounting holes ( $P$ ). At the same time, the value  $E_{1/2}$  should be between  $E_{1/2}$  min and  $E_{1/2}$  max so that the mounting hole does not rupture.

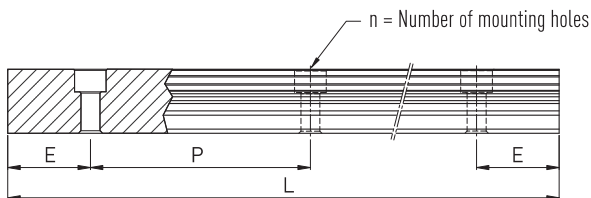

**F 3.11**  $L = (n - 1) \times P + E_1 + E_2$

- $L$  Total length of the rail [mm]
- $n$  Number of mounting holes
- $P$  Distance between two mounting holes [mm]
- $E_{1/2}$  Distance from the middle of the last mounting hole to the end of the rail [mm]

# Linear guideways

## WE/QW series

### 3.4.9.3 Tightening torques for mounting bolts

Insufficient tightening of the mounting bolts compromises the function and precision of the linear guideways. The following tightening torques are recommended for the screw sizes.

Table 3.65 Tightening torques of the mounting bolts according to ISO 4762-12.9

Series/size	Screw size	Torque [Nm]	Series/size	Screw size	Torque [Nm]
WE_17	M4	4	WE/QW_35	M6	13
WE/QW_21	M4	4	WE_50	M8	30
WE/QW_27	M4	4			

### 3.4.9.4 Cover caps for mounting holes of rails

The cover caps are used to keep the mounting holes free of chips and dirt. The standard plastic caps are provided with each rail. Optional cover caps must be ordered separately.

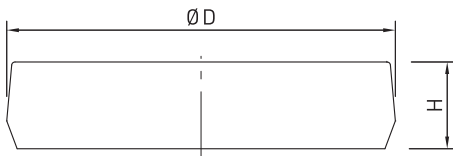

Table 3.66 Cover caps for mounting holes of rails

Rail	Screw	Article number			Ø D [mm]	Height H [mm]
		Plastic (200 pcs.)	Brass	Steel		
WER17R	M4	5-002218	5-001344	—	7.5	1.2
WER21R	M4	5-002218	5-001344	—	7.5	1.2
WER27R	M4	5-002218	5-001344	—	7.5	1.2
WER35R	M6	5-002221	5-001355	5-001357	11.0	2.8
WER50R	M8	5-002222	5-001360	5-001362	14.0	3.5

### 3.4.10 Sealing systems

Various sealing systems are available for HIWIN blocks. You will find an overview on [Page 22](#). The table below shows the total length of the blocks with the different sealing systems. Sealing systems suitable for these sizes are available.

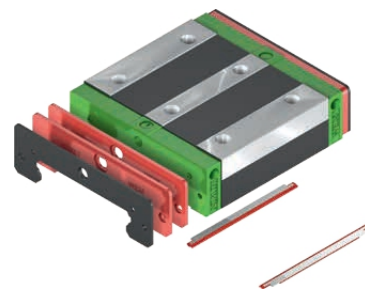

Table 3.67 Total length of block with different sealing systems

Series/size	Total length L			
	SS	DD	ZZ	KK
WE_17C	50.6	53.8	52.6	55.8
WE/QW_21C	59.0	63.0	61.0	65.0
WE/QW_27C	72.8	76.8	74.8	78.8
WE/QW_35C	102.6	106.6	105.6	109.6
WE_50C	140.0	145.0	142.0	147.0

Unit: mm



### 3.4.11 Designation of sealing sets

The sealing sets are always supplied along with the assembly material and include the parts needed in addition to the standard seal.

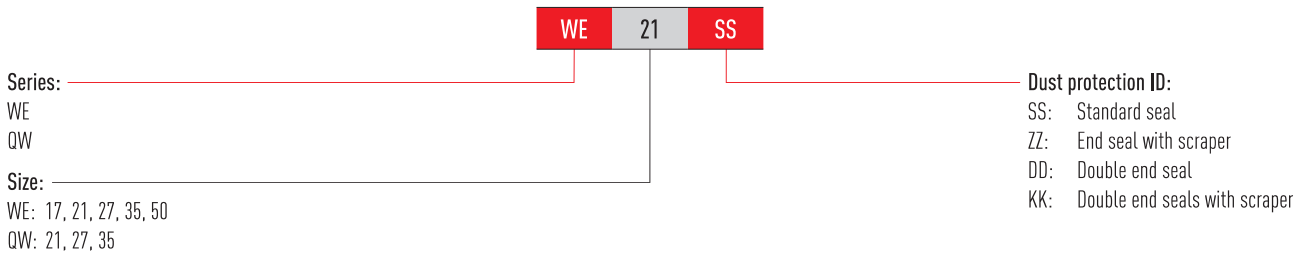

### 3.4.12 Friction

The table shows the maximum frictional resistance of the individual end seal. Depending on sealing setup (SS, ZZ, DD, KK), the value may have to be multiplied. The values indicated apply to blocks on uncoated rails. Higher friction forces occur on coated rails.

Series/size	Friction force [N]	Series/size	Friction force [N]
WE_17	1.2	WE/QW_35	3.9
WE/QW_21	2.0	WE_50	3.9
WE/QW_27	2.9		

# Linear guideways

## WE/QW series

### 3.4.13 Tolerances depending on accuracy class

The WE and QW series are available in five accuracy classes depending on parallelism between block and rail, height accuracy H and accuracy of width N. The choice of accuracy class is determined by the machine requirements.

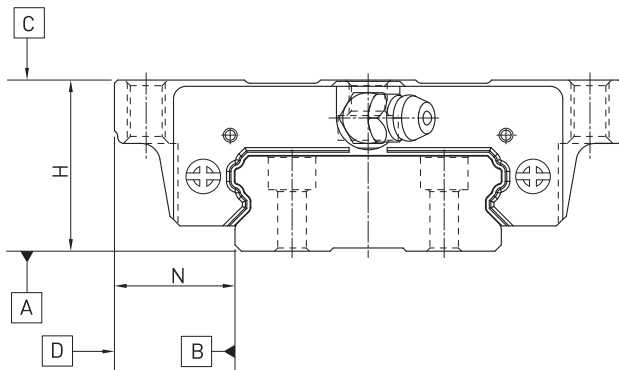

### 3.4.14 Parallelism

Parallelism of stop surfaces D and B of block and rail and parallelism of top of block C to mounting surface A of rail. Ideal linear guideway installation is required, as is a measurement in the centre of the block.

Table 3.69 Tolerance of parallelism between block and rail

Rail length [mm]	Accuracy class				
	C	H	P	SP	UP
- 100	12	7	3	2	2
100 - 200	14	9	4	2	2
200 - 300	15	10	5	3	2
300 - 500	17	12	6	3	2
500 - 700	20	13	7	4	2
700 - 900	22	15	8	5	3
900 - 1100	24	16	9	6	3
1100 - 1500	26	18	11	7	4
1500 - 1900	28	20	13	8	4
1900 - 2500	31	22	15	10	5
2500 - 3100	33	25	18	11	6
3100 - 3600	36	27	20	14	7
3600 - 4000	37	28	21	15	7

Unit:  $\mu\text{m}$

### 3.4.14.1 Accuracy – height and width

#### Height tolerance of H

Permissible absolute dimension variance of height H, measured between centre of screw-on surface C and underside of rail A, with block in any position on the rail.

#### Height variance of H

Permissible variance of height H between several blocks on a rail, measured in the same rail position.

#### Width tolerance of N

Permissible absolute dimension variance of width N, measured between centre of screw-on surfaces D and B, with block in any position on the rail.

#### Width variance of N

Permissible variance of width N between several blocks on a rail, measured in the same rail position.

Table 3.70 Height and width tolerances

Series/size	Accuracy class	Height tolerance of H	Width tolerance of N	Height variance of H	Width variance of N
<b>WE_17, 21</b> <b>QW_21</b>	C (Normal)	± 0.1	± 0.1	0.02	0.02
	H (High)	± 0.03	± 0.03	0.01	0.01
	P (Precision)	0/− 0.03 <sup>1)</sup> ± 0.015 <sup>2)</sup>	0/− 0.03 <sup>1)</sup> ± 0.015 <sup>2)</sup>	0.006	0.006
	SP (Super precision)	0/− 0.015	0/− 0.015	0.004	0.004
	UP (Ultra precision)	0/− 0.008	0/− 0.008	0.003	0.003
<b>WE_27, 35</b> <b>QW_27, 35</b>	C (Normal)	± 0.1	± 0.1	0.02	0.03
	H (High)	± 0.04	± 0.04	0.015	0.015
	P (Precision)	0/− 0.04 <sup>1)</sup> ± 0.02 <sup>2)</sup>	0/− 0.04 <sup>1)</sup> ± 0.02 <sup>2)</sup>	0.007	0.007
	SP (Super precision)	0/− 0.02	0/− 0.02	0.005	0.005
	UP (Ultra precision)	0/− 0.01	0/− 0.01	0.003	0.003
<b>WE_50</b>	C (Normal)	± 0.1	± 0.1	0.03	0.03
	H (High)	± 0.05	± 0.05	0.02	0.02
	P (Precision)	0/− 0.05 <sup>1)</sup> ± 0.025 <sup>2)</sup>	0/− 0.05 <sup>1)</sup> ± 0.025 <sup>2)</sup>	0.01	0.01
	SP (Super precision)	0/− 0.03	0/− 0.03	0.01	0.01
	UP (Ultra precision)	0/− 0.02	0/− 0.02	0.01	0.01

Unit: mm

<sup>1)</sup> Fully assembled linear guideway

<sup>2)</sup> Unmounted linear guideway

# Linear guideways

WE/QW series, MG series

### 3.4.14.2 Permissible mounting surface tolerances

Once the requirements relating to the accuracy of the mounting surfaces are met, the good accuracy, rigidity and lifetime of the WE and QW series linear guideways are achieved.

#### Parallelism of the reference surface (P):

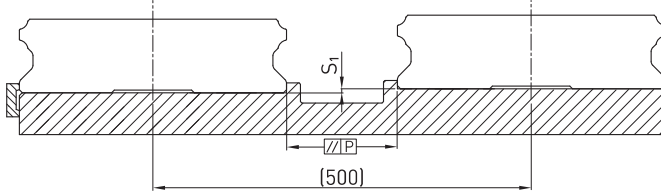

Table 3.71 Maximum tolerance for parallelism (P)

Series/size	Preload class		
	Z0	ZA	ZB
WE_17	20	15	9
WE/QW_21	25	18	9
WE/QW_27	25	20	13
WE/QW_35	30	22	20
WE_50	40	30	27

Unit:  $\mu\text{m}$

Table 3.72 Maximum tolerance for height of reference surface ( $S_1$ )

Series/size	Preload class		
	Z0	ZA	ZB
WE_17	65	20	—
WE/QW_21	130	85	45
WE/QW_27	130	85	45
WE/QW_35	130	85	70
WE_50	170	110	90

Unit:  $\mu\text{m}$

### 3.4.15 Shoulder heights and fillets

Imprecise shoulder heights and fillets of mounting surfaces compromise precision and may lead to conflicts with the block or rail profiles. The following shoulder heights and edge profiles must be observed in order to avoid assembly problems.

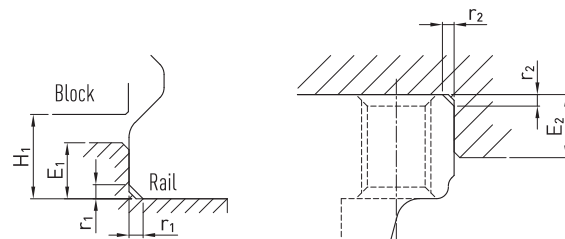

Table 3.73 Shoulder heights and fillets

Series/size	Max. edge radius $r_1$	Max. edge radius $r_2$	Shoulder height of reference edge of rail $E_1$	Shoulder height of reference edge of block $E_2$	Clearance under block $H_1$
WE_17	0.4	0.4	2.0	4.0	2.5
WE/QW_21	0.4	0.4	2.5	5.0	3.0
WE/QW_27	0.5	0.5	3.0	7.0	4.0
WE/QW_35	0.5	0.5	3.5	10.0	4.0
WE_50	0.8	0.8	6.0	10.0	7.5

Unit: mm