

## 1. Connector assignment EOT-4 CLOSED LOOP SYSTEM

M16 Built-in connector 6 PIN (Stepper motor + oscillation motor):

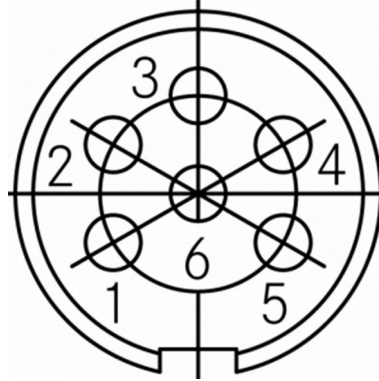

View on termination side of male contact insert (Cable side)  
Contact diameter 1,5 mm

PIN		Cable color	Function / description	Note
1	Stepper motor	BLACK	A	I.
2		RED	A/	
3		YELLOW	B	
4		BLUE	B/	
5	DC oscillation motor	RED	+12V DC to +24V DC oscillation motor	II.
6		BLACK	0V DC oscillation motor	

The attached notes I. - IV. must be observed.



### Cable socket for connection:

**ECOCAM order no. 300050**

Cable socket M16, 6 PIN, contact diameter 1,5 mm, shieldable, metal housing, cable diameter 8-10,5mm

### Socket crimp contacts (Contact diameter 1,5 mm):

0,14 - 0,25mm<sup>2</sup> / AWG 26 -24 **order no. 300300**

0,35 - 0,5mm<sup>2</sup> / AWG 22-20 **order no. 300400**

0,75 - 1,0mm<sup>2</sup> / AWG18 **order no. 300500**

**M16 Built-in connector 12 PIN (Reference position sensor + Closed-loop-system):**

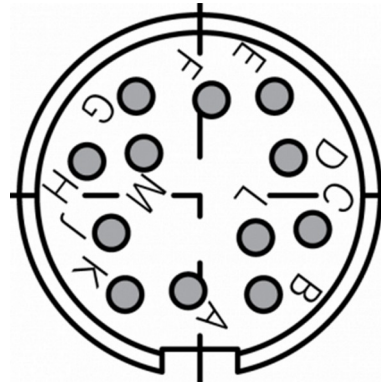

View on termination side of male contact insert (Cable side)  
Contact diameter 1,0 mm

PIN		Kabelfarbe	Funktion / Beschreibung	Hinweis
A	Reference position sensor	RED	+6 to +24V DC electronics for reference position sensor	III.
B		BLACK	0V DC electronics for reference position sensor	
C		YELLOW	Relay - Base	
D		BROWN	Relay - Output A	
E		BLUE	Relay - Output B	
F	Closed loop system	WHITE	GND	IV.
G		RED	VCC (5V)	
H		BLUE	A+	
J		BLACK	A-	
K		GREEN	B+	
L	YELLOW	B-		
M	-	-	N.N.	-

The attached notes I. - IV. must be observed.



**Cable socket for connection:**

**ECOCAM order no. 300220**

Cable socket M16, 12 PIN, contact diameter 1,5 mm, shieldable, metal housing, cable diameter 8-10,5mm

**Socket crimp contacts (Contact diameter 1,0 mm):**

0,14 - 0,25mm<sup>2</sup> / AWG 26 -24 order no. 300250

## 2. Notes to the connector assignment

Hinweis	Beschreibung
I.	The connection of the stepper motor depends on the motor driver. The attached stepper motor data and the technical documentation for the motor driver must be observed.
II.	At a voltage of 24V, the oscillation frequency is approx. 7000 strokes per minute. The nominal voltage is 12V; the maximum voltage is 24V. Speed, oscillation frequency and current consumption increase with increasing voltage. The DC oscillation motor must be fused externally; the maximum current must not exceed 2.8 A.
III.	<p>The electronic system for the position sensor has to be supplied with a direct current of 6V to 24V. Electronics have to be fused externally; the maximum current must not exceed 500mA</p> <p>The position sensor controls an integrated relay that can be used by the supervising CNC controller as a limit or reference switch:</p> <ul style="list-style-type: none"> <li>• Once the blade has reached the homing point during a reference run, there is contact between <b>PIN C</b> and <b>PIN F</b> of the 12-pole M16 connector.</li> <li>• If the blade is located outside the reference position, there is contact between <b>PIN C</b> and <b>PIN E</b> of the 12-pole M16 connector.</li> <li>• Depending on the applied CNC controller, the integrated relay can be used as a normally closed switch (NC) or as a normally open switch (NO).</li> <li>• The switching voltage of the relay must not exceed 24V DC; the maximum switching current must not exceed 500mA.</li> </ul>
IV.	The attached encoder data and the technical documentation for the motor driver must be observed. The encoder is typically supplied with power via the closed-loop motor driver.

### Warning !



The electrical and mechanical connection of the processing unit has to be done with utmost accuracy by an expert only. It is not allowed to put the unit in operation before all necessary and required country-specific safety regulations have been observed and checked carefully. Only the operator of the facility (i.e. machining system) is responsible for observing all relevant safety regulations.

### 3. Stepper motor data :

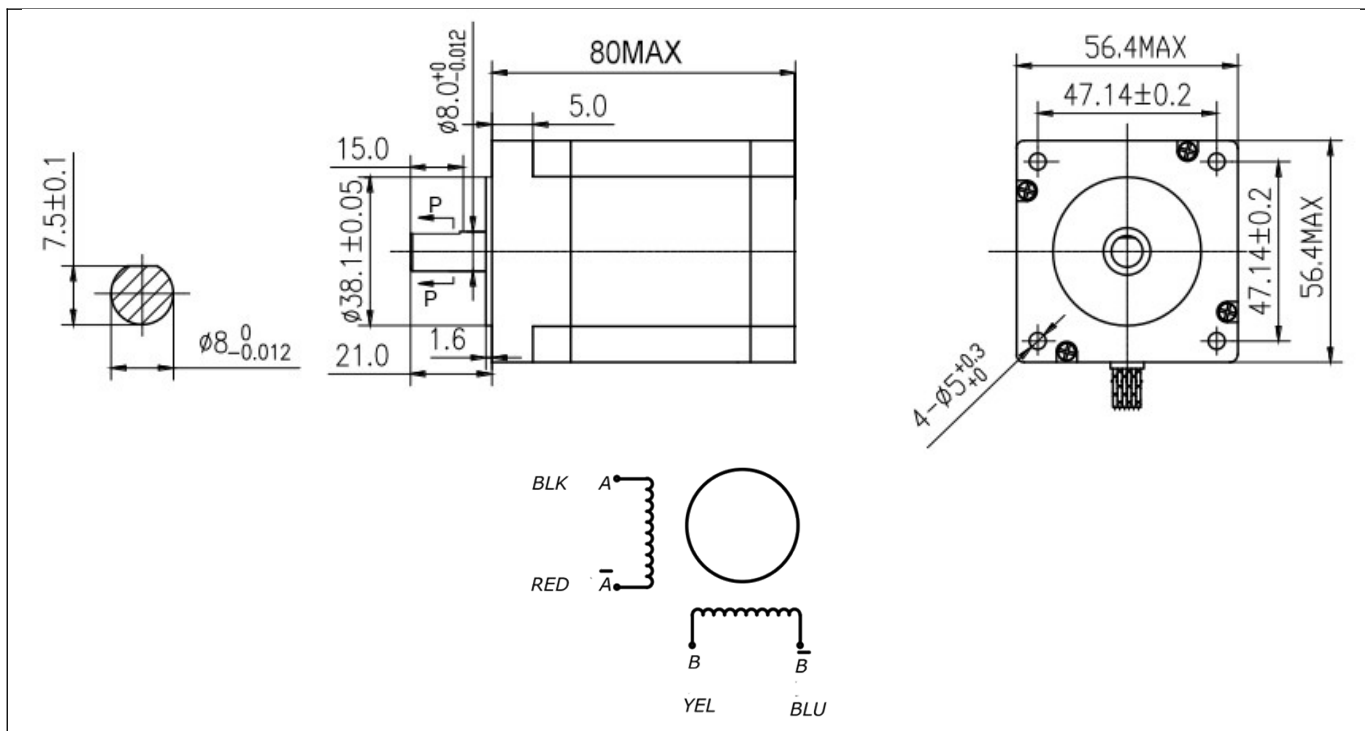

#### SPECIFICATIONS

<b>Phase</b>	2 Phase		
<b>STEP ANGLE</b>	1,8° +/- 5% / STEP		
<b>Voltage</b>	2.4 V		
<b>CURRENT</b>	4.0 A / PHASE		
<b>RESISTANCE</b>	0.6 +/- 10% OHM / PHASE		
<b>INDUCTANCE</b>	2.5 +/- 20% mH / PHASE		
<b>HOLDING TORQUE</b>	2.1 Nm MIN		
<b>DETENT TORQUE</b>	6.8 Ncm MAX		
<b>INSULATION CLASS</b>	B		
<b>LEAD STYLE</b>	AWG18 UL1332		
<b>ROTOR TORQUE</b>	480 gcm <sup>2</sup>		
<b>ENCODER RESOLUTION</b>	1000 INC. / REV.		
<b>WIRING STEPPER MOTOR</b>		<b>WIRING ENCODER</b>	
<b>A</b>	BLK	<b>GND</b>	WHT
<b>A/</b>	RED	<b>VCC</b>	RED
<b>B</b>	YEL	<b>A+</b>	BLU
<b>B/</b>	BLU	<b>A-</b>	BLK
		<b>B+</b>	GRN
		<b>B-</b>	YEL

**4. Cable sockets and crimp contacts**

Cable socket M16, **6 PIN**  
**ECOCAM order no. 300050**

- contact diameter **1,5 mm**
- metal housing
- shieldable
- cable diameter 8-10,5mm



Cable socket M16, **12 PIN**  
**ECOCAM order no. 300220**

- contact diameter **1,0 mm**
- metal housing
- shieldable
- cable diameter 8-10,5mm

**Compatible socket crimp contacts:**

**Order no. 300300**  
0,14 - 0,25mm<sup>2</sup> / AWG 26 -24  
Contact diameter 1,5mm

**Order no. 300400**  
0,35 - 0,5mm<sup>2</sup> / AWG 22-20  
Contact diameter 1,5mm

**Order no. 300500**  
0,75 - 1,0mm<sup>2</sup> / AWG18  
Contact diameter 1,5mm



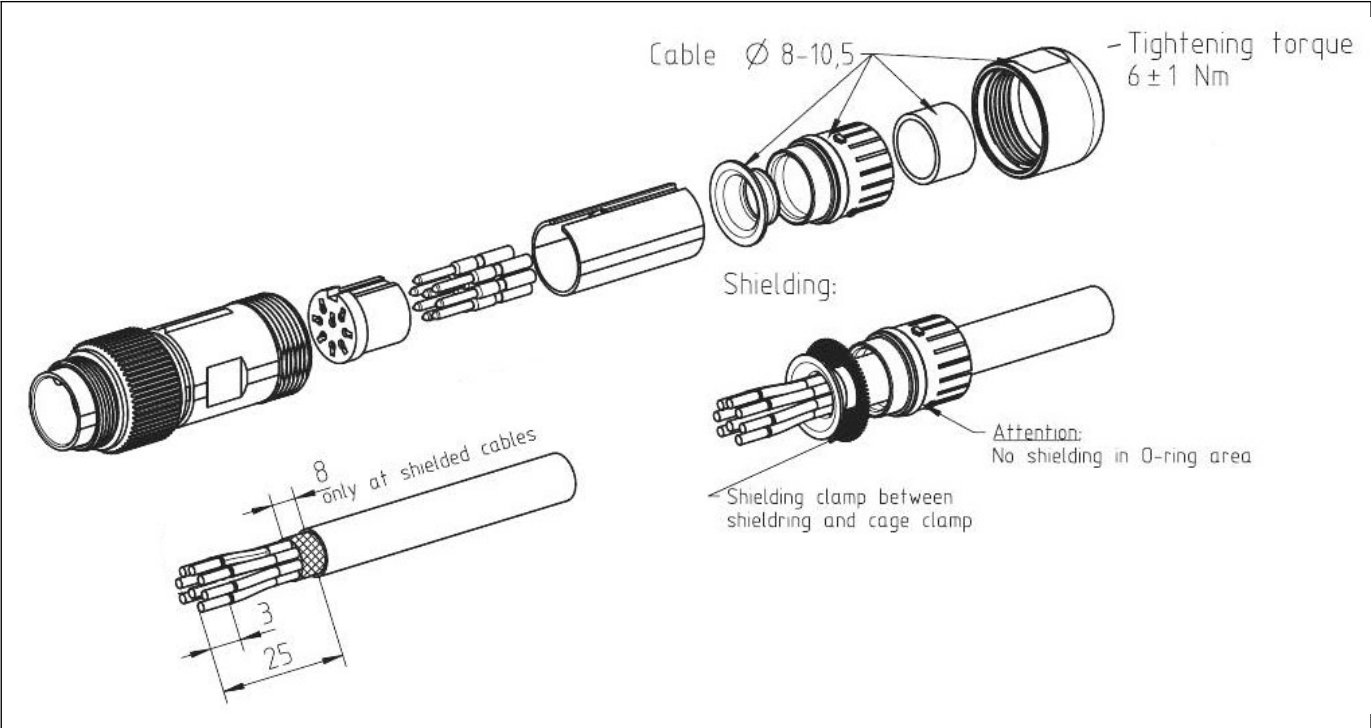

**Compatible socket crimp contacts:**

**Order no. 300220**  
0,14 - 0,25mm<sup>2</sup> / AWG 26 -24  
Contact diameter 1,0mm

## 5. Cable- and cable socket assembly



**6. Overview and technical data socket crimp contacts**

Order number	Contact diameter	Connecting range	Wire gauge		Stripping length	Crimp height - Average values	Crimp retention force acc. DIN EN 60352-2
	mm		mm <sup>2</sup>	mm <sup>2</sup>			
<b>#300250</b> 	1	0,14 - 0,25	0,14		3,0 + 0,5	0,86 - 0,9	18
				24			28
			0,25			0,91 - 0,97	32
<b>#300300</b> 	1,5	0,14 - 0,25	0,14		3,0 + 0,5	0,86 - 0,9	18
				24			28
			0,25			0,91 - 0,97	32
<b>#300400</b> 	1,5	0,35 - 0,50	0,35	22	3,0 + 0,5	0,90 - 1,06	40
			0,50	20		0,95 - 1,11	60
<b>#300500</b> 	1,5	0,75 - 1,00	0,75		3,5 + 1,0	1,33 - 1,50	85
				18			90
			1,00			1,36 - 1,53	108

## **© Copyright**

ECOCAM CNC - Inh. R. Skowron

All previous versions lose their validity with this document. The information in this document is subject to change without notice. All rights reserved. No part of this document may be reproduced or transmitted in any form or by any means, electronic or mechanical, including photocopying, recording or otherwise, without the express written permission of the copyright owner. Although every care has been taken to avoid mistakes or printing errors, these cannot be ruled out. We would be grateful for any suggestions for improvements or information on possible mistakes or unclear formulation. 22.08.24