

1

2

3

4

5

6

RevNo	Revision note		Date	Signature	Checked
-------	---------------	--	------	-----------	---------

A

A

B

B

C

C

D

D

Suitable for  $\varnothing 12\text{mm}$  ballscrews

M8x1 Metric Fine Thread

$-0.008$   
 $\varnothing 8$   
 $-0.015$

$+0.00$   
 $\varnothing 6$   
 $-0.012$

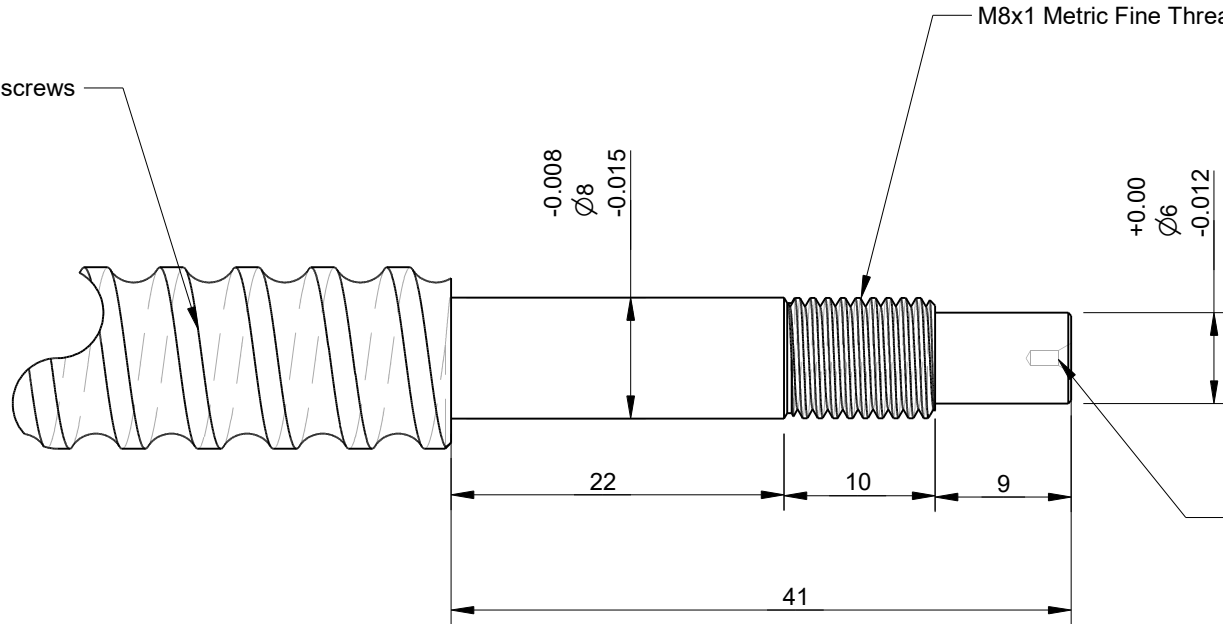

DIN333 Form A Centre Drill hole  
Not always present. This is used for  
manufacturing purposes only.

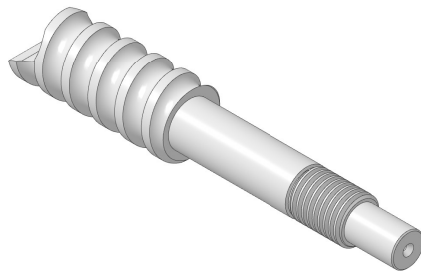

Itemref	Quantity	Title/Name, designation, material, dimension etc			Article No./Reference	
Drawn by Kevin Damen		Checked by	Approved by - date 12-6-2024	File name	Date 29-5-2024	Scale 2:1

Units: mm  
Tolerances: +/- 0.1mm unless otherwise specified  
WARNING: Ballscrew not included in the delivery

# 8108

[www.damencnc.com](http://www.damencnc.com)

8108 EK-FK-FKA08 Ballscrew End Machinig Fixed side	Edition	Sheet 1 OF 1
---	---------	-----------------

1

2

3

4

5

6