

# Chapter 8 Option Cards

---

- 8-1 Option Card Installation
- 8-2 CMM-PD02 -- Communication Extension Card, PROFIBUS DP
- 8-3 CMM-DN02 -- Communication Extension Card, DeviceNet
- 8-4 CMM-EIP02 -- Communication Extension Card, EtherNet/IP
- 8-5 CMM-COP02 -- Communication Extension Card, CANopen
- 8-6 CMM-EC02 -- Communication Extension Card, EtherCAT
- 8-7 EMM-BPS02 -- +24 V Power Card
- 8-8 Delta Standard Fieldbus Cables

The option cards in this chapter are optional accessories. Select the applicable option cards for your motor drive, or contact your local distributor for suggestions. The option cards can significantly improve the efficiency of the motor drive. To prevent damage to the motor drive during installation, remove the digital keypad and the cover before wiring.

## 8-1 Option Card Installation

### Mounting Position of Option Cards

Frame A–D

Mounting position 1, 2 (Option card mounting box)

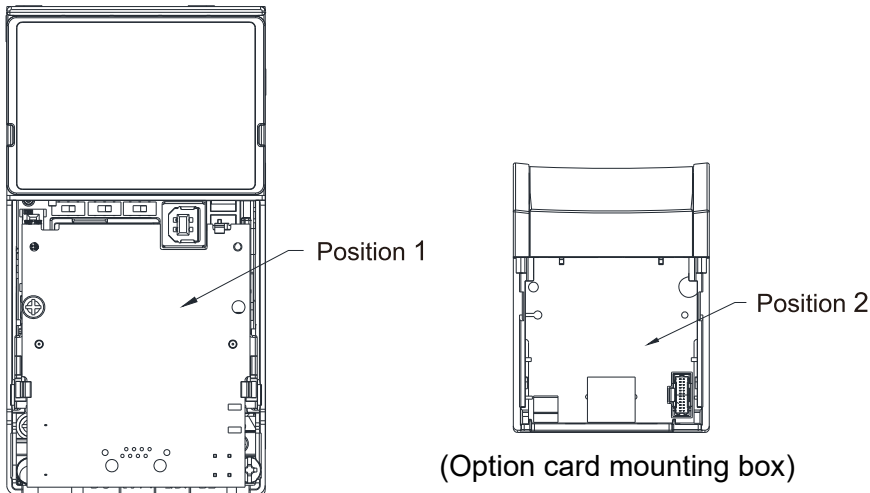

Figure 8-1

Frame E and F

Mounting position 1

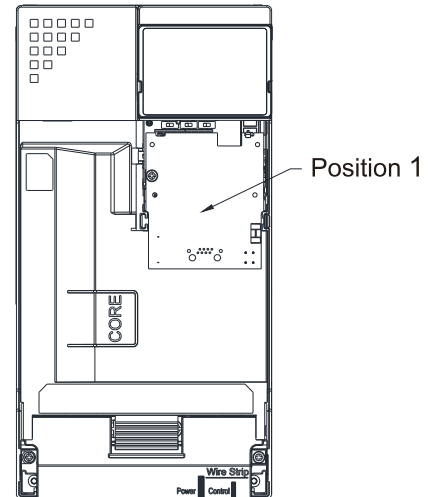

Figure 8-2

Note: Frame E and F does not support a second option card installation, so there is no mounting position 2.

### The Wiring of Option Cards

MS300 control board connector

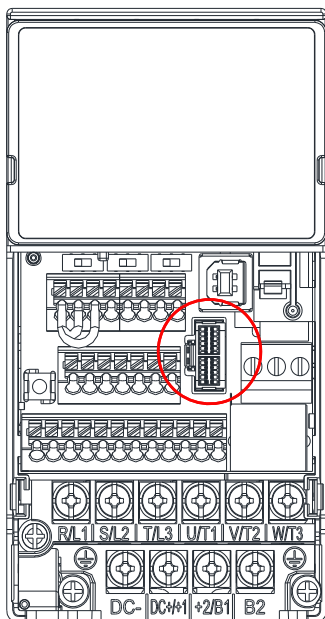

Figure 8-3

Option card connector

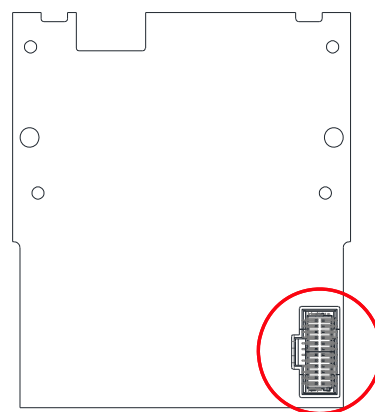

Figure 8-4

Attention: Do NOT misuse the cables for the communication cards and the cables for the power card. You must read the descriptions on the cables before wiring.

● **Communication Card Cables**

To correctly use the communication cards, you must purchase the communication card along with the connection cables. Check your communication card models first. Then, select your applicable connection cables according to the mounting positions by different frames. Two cable length are available for your choice. See the table below to select your applicable communication card cables.

Communication Card	CMM-DN02, CMM-EIP02, CMM-PD02, CMM-COP02		CMM-EC02	
	Mounting Position 1	Mounting Position 2	Mounting Position 1	Mounting Position 2
Frame	Cable Model#	Cable Model#	Cable Model#	Cable Model#
A	CBM-CL01A	CBM-CC01A	CBM-CL01A	CBM-CL01A
B		CBM-CC02A		CBM-CL02A
C	CBM-CL02A		N/A	
D				
E				
F				

 **NOTE**

An option card mounting box is included upon purchasing the communication card CMM-EC02, you need to purchase it with CBM-CL01A or CBM-CL02A

CBM-CL01A  
CBM-CC01A

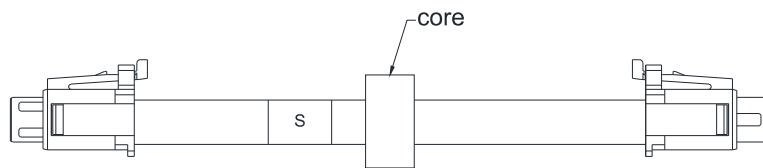

Figure 8-5

CBM-CL02A  
CBM-CC02A

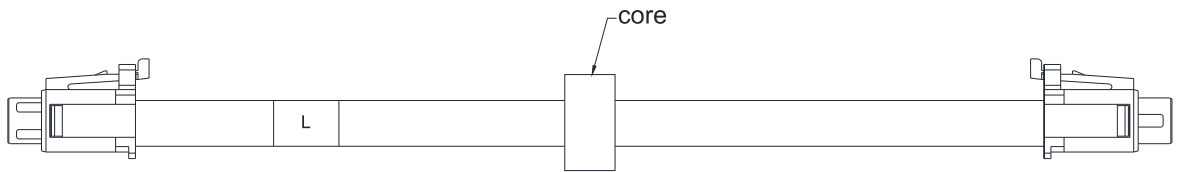

Figure 8-6

● **Power Card Cables**

An option card mounting box and cables with two different length are included when you purchase the power card EMM-BPS02 (DC 24 V backup power supply card), so you do not need to purchase it with the connection cables. “**BPS use only**” and “# S” or “# L” are marked on the EMM-BPS02 power card cable. See the table below to select your applicable power card cables according to different mounting positions.

Power Card	EMM-BPS02	
Frame	Mounting Position 1	Mounting Position 2
	Cable Model#	Cable Model#
A	# S	# S
B		# L
C	# L	
D	# L	
E	# L	N/A
F		

# S

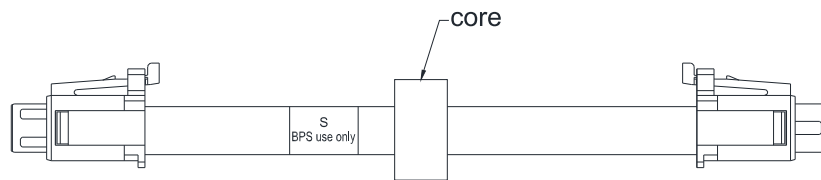

Figure 8-7

# L

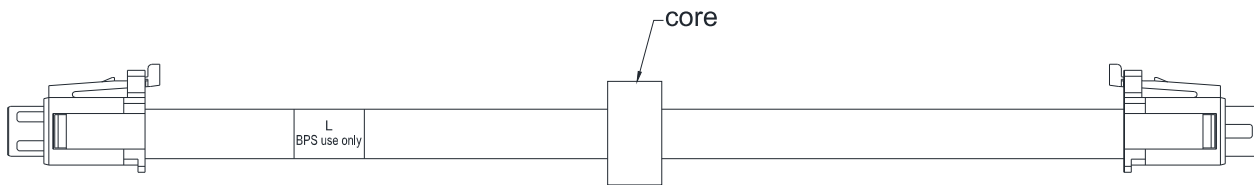

Figure 8-8

## Option Card Mounting Position 1

Installation method: **Back-mount** the option card by connecting **flat cables** to the control board.

1. Turn off the power of the motor drive, and then remove the front cover, as shown in Figure 8-9.
2. Assemble the connection cable: Connect the connector at one end of the connection cable to the control board connector. Refer to Section 8-1 **The Wiring of Option Cards** for more information on connection methods.
3. Assemble the supported frame of the option card: Aim the two clips at the two slots on the motor drive, and then press downward to have the two clips engage the slots, as shown in Figure 8-10.
4. Assemble the connection cable: Connect the connector at the other end of the connection cable to the connector of the option card.
5. Assemble the option card: Have the terminal block and connector of the option card face downward, aim the two holes of the option card to the position column and press downward so that the three clips engage the option card, as shown in Figure 8-11.
6. Make sure that three clips properly engage the option card and then tighten the screws (suggested torque value: 4–6 kg-cm [3.5–5.2 lb-in.] [0.39–0.59 Nm]), as shown in Figure 8-12.
7. Assembly is completed, as shown in Figure 8-13.

(Take communication card as an example)

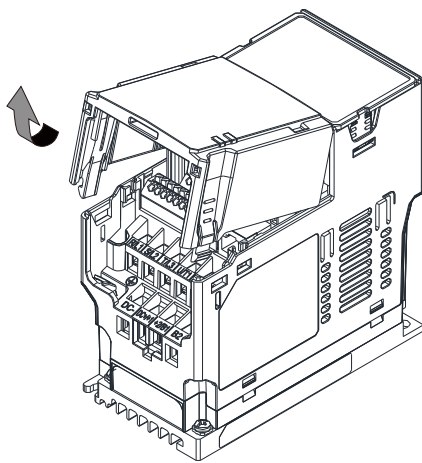

Figure 8-9

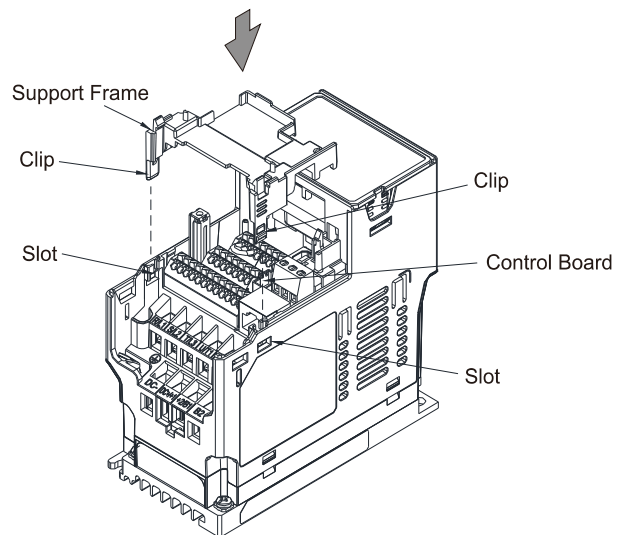

Figure 8-10

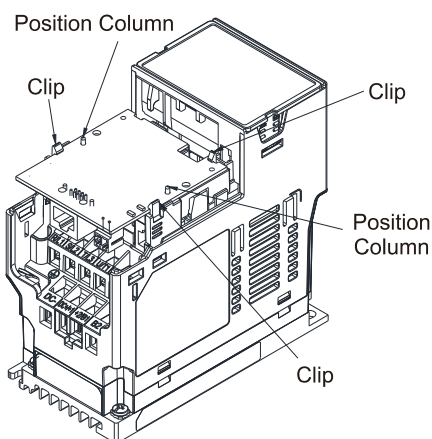

Figure 8-11

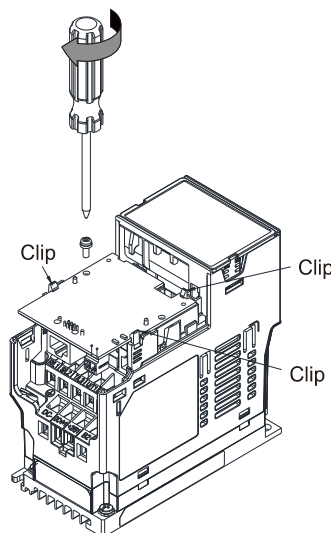

Figure 8-12

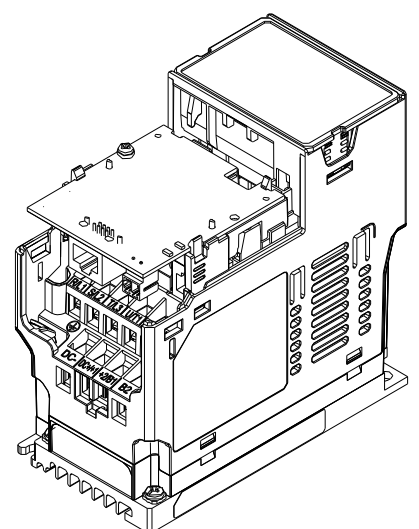

Figure 8-13

### Option Card Mounting Position 2 (Frame A–D)

Installation method: **Front-mount** the option card by connecting **flat cables** to the control board.

1. Turn off the power of the motor drive and then remove the front cover, as shown in Figure 8-14.
2. Assemble the option card: Detach the upper cover of the mounting box for the option card by slipping and make the terminal block and connector of the option card face upward. Fix the front end of the option card to the slots, and then rotate it, as shown in the Figure 8-15.
3. Make sure that two clips properly engage the option card on the backside, and then tighten the screws (suggested torque value: 4–6 kg-cm [3.5–5.2 lb-in.] [0.39–0.59 Nm]), as shown in Figure 8-16.
4. Assemble the connection cable: Connect the connector at one end of the connection cable to the control board connector. Refer to Section 8-1 **The Wiring of Option Cards** for more information on connection methods.
5. Attach the front cover of the drive.
6. Assemble the connection cable: Connect the connector at the other end of the connection cable to the connector of the option card.
7. Attach the upper cover to the mounting box for the option card, as shown in Figure 8-17.
8. Assemble the mounting box for the option card: Aim the four clips of the mounting box for the option card at the slots on the upper cover of the motor drive, and then press downward to have the four clips engage the slots, as shown in the Figure 8-18.
9. Assembly is completed, as shown in Figure 8-19.

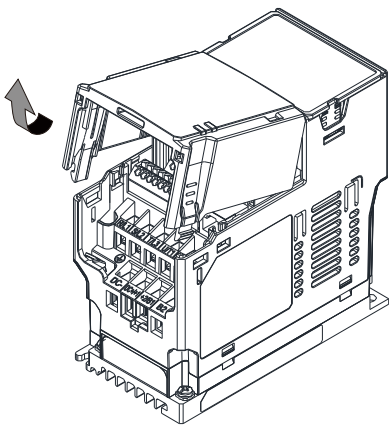

Figure 8-14

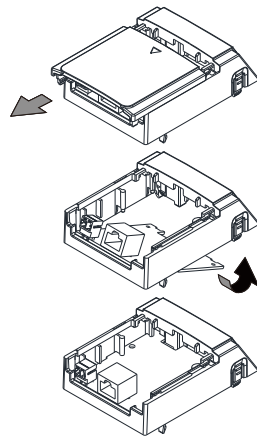

Figure 8-15

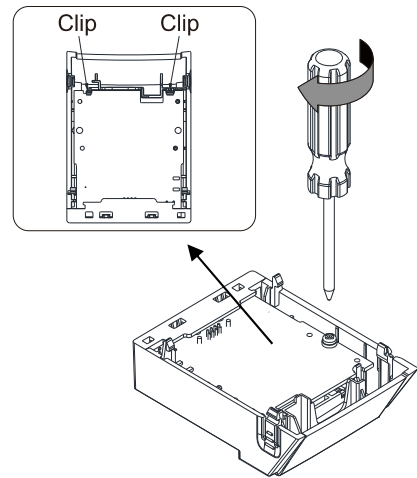

Figure 8-16

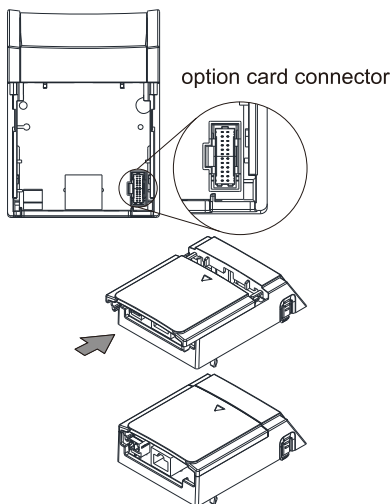

Figure 8-17

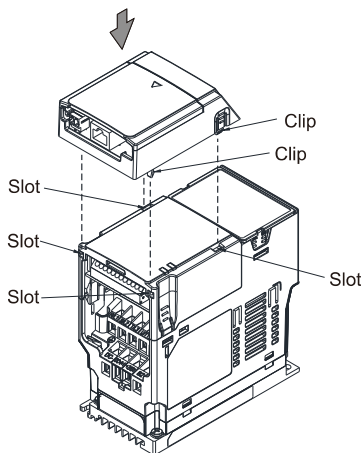

Figure 8-18

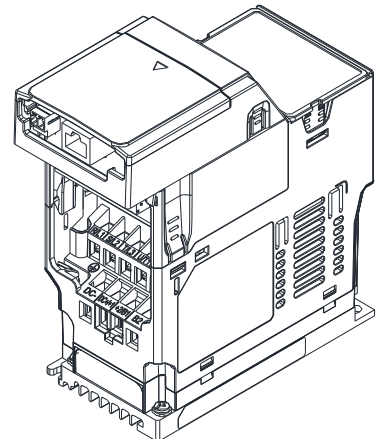

Figure 8-19

### Grounded installation

- You must ground the option cards as listed below when wiring. The ground terminal is included in the option card package, as shown in Figure 8-20.

- CMM-PD02
- CMM-DN02
- CMM-EIP02
- CMM-COP02
- CMM-EC02
- EMM-BPS02

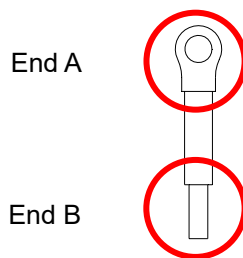

Figure 8-20

- Installation of the ground terminal:

The B end of the grounding wire connects to the ground terminal block of the option card, as the No.6 shows in Figure 8-21 (see Chapter 8 for the ground terminal block position of other option cards). The A end of the grounding wire connects to the drive's PE, as the circles show in Figure 8-22 and Figure 8-23.

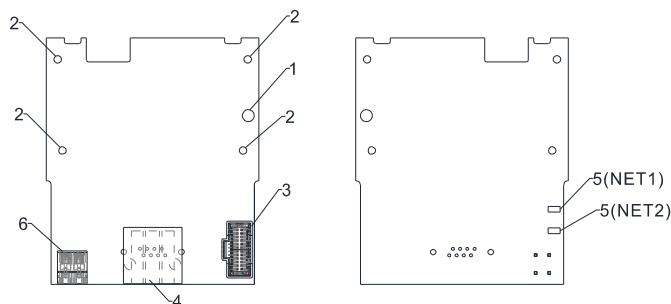

Figure 8-21

#### Frame A–C

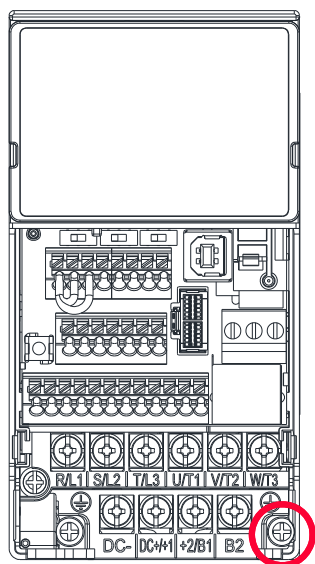

Figure 8-22

#### Frame D–F

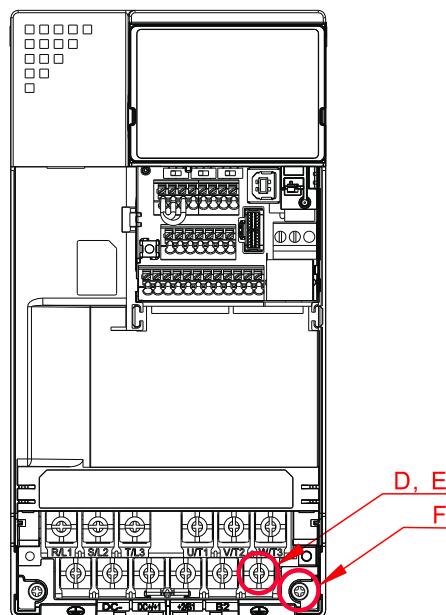

Figure 8-23

Frame	Screw Spec.	Torque (±10%)
A	M3.5	9 kg-cm [7.8 lb-in] [0.88 Nm]
B	M4	15 kg-cm [13.0 lb-in] [1.47 Nm]
C	M4	20 kg-cm [17.4 lb-in] [1.96 Nm]

Frame	Screw Spec.	Torque (±10%)
D	M4	20 kg-cm [17.4 lb-in] [1.96 Nm]
E	M5	25 kg-cm [21.7 lb-in] [2.45 Nm]
F	M4	20 kg-cm [17.4 lb-in] [1.96 Nm]

## 8-2 CMM-PD02

### Product Profile

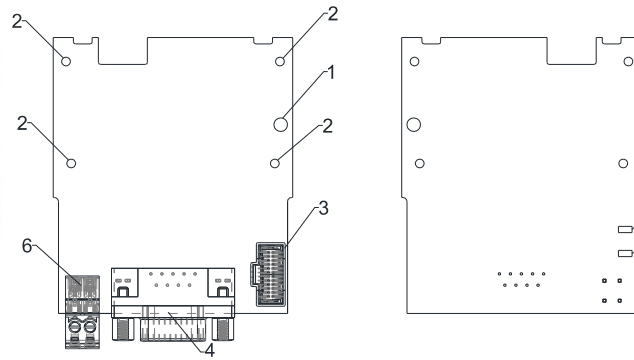

1. Screw fixing hole
2. Positioning hole
3. AC motor drive connection port
4. Communication port
5. Indicator NET1, NET2
6. Ground terminal block

Wire gauge: 0.25–0.5 mm<sup>2</sup> [24–20 AWG]

Stripping length: 7–8 mm

Screw torque: 2 kg-cm / [1.7 lb-in.] / [0.2 Nm]

### Features

1. Supports PZD control data exchange.
2. Supports PKW access AC motor drive parameters.
3. Supports user diagnosis function.
4. Auto-detects baud rates; supports a maximum of 12 Mbps.

### Specifications

#### PROFIBUS DP Connector

Interface	DB9 connector
Transmission method	High-speed RS-485
Transmission cable	Shielded twisted-pair cable
Electrical isolation	500 V <sub>DC</sub>

#### Communication

Message type	Cyclic data exchange
Module name	CMM-PD02
GSD document	DELA08DB.GSD
Product ID	08DB (HEX)
Serial transmission speed supported (auto-detection)	9.6 kbps; 19.2 kbps; 93.75 kbps; 187.5 kbps; 500 kbps; 1.5 Mbps; 3 Mbps; 6 Mbps; 12 Mbps (bits per second)

#### Electrical Specification

Power supply voltage	15 V <sub>DC</sub> (supplied by the AC motor drive)
Insulation voltage	500 V <sub>DC</sub>
Power consumption	1 W
Weight	28 g



## Environment

Noise immunity	ESD (IEC 61800-5-1, IEC 6100-4-2) EFT (IEC 61800-5-1, IEC 6100-4-4) Surge Test (IEC 61800-5-1, IEC 6100-4-5) Conducted Susceptibility Test (IEC 61800-5-1, IEC 6100-4-6)
Operation / storage	Operation: -10–50°C (temperature), 90% (humidity) Storage: -25–70°C (temperature), 95% (humidity)
Shock / vibration resistance	International standards: IEC 61131-2, IEC 68-2-6 (TEST Fc) / IEC 61131-2 & IEC 68-2-27(TEST Ea)

## ■ Installation

### PROFIBUS DP Connector

PIN	Signal	Definition
1	-	Not defined
2	-	Not defined
3	Rxd / Txd-P	Sending / receiving data P(B)
4	-	Not defined
5	DGND	Data reference ground
6	VP	Power voltage – positive
7	-	Not defined
8	Rxd / Txd-N	Sending / receiving data N(A)
9	-	Not defined

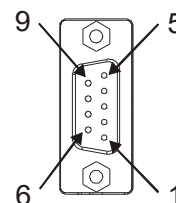

## ■ LED Indicator & Troubleshooting

There are two LED indicators on the CMM-PD02: POWER LED and NET LED. POWER LED displays the status of the working power. NET LED displays the connection status of the communication.

### POWER LED

LED status	Indication	Corrective Action
Green light on	Power supply in normal status.	No action is required.
Off	No power	Check if the connection between the CMM-PD02 and the AC motor drive is normal.

### NET LED

LED status	Indication	Corrective Action
Green light on	Normal status	No action is required.
Red light on	The CMM-PD02 is not connected to PROFIBUS DP bus.	Connect the CMM-PD02 to the PROFIBUS DP bus.
Red light flashes	Invalid PROFIBUS communication address	Set the PROFIBUS address of the CMM-PD02 between 1–125 (decimal).
Orange light flashes	The CMM-PD02 fails to communicate with the AC motor drive.	Switch off the power and check whether the CMM-PD02 is correctly installed and normally connected to the AC motor drive.

### 8-3 CMM-DN02

#### Product Profile

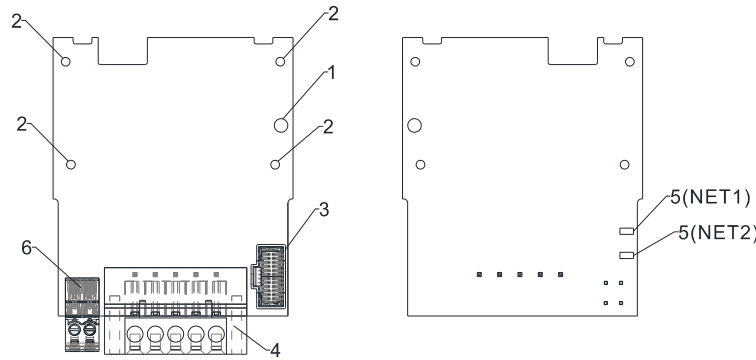

1. Screw fixing hole
2. Positioning hole
3. AC motor drive connection port
4. Communication Port
5. Indicator NET1, NET2
6. Ground terminal block

Wire gauge: 0.25–0.5 mm<sup>2</sup> [24–20 AWG]  
 Stripping length: 7–8 mm  
 Screw torque: 2 kg-cm / [1.7 lb-in.] / [0.2 Nm]

#### Features

1. Based on the high-speed communication interface of Delta’s HSSP protocol, the AC motor drive can be controlled in real-time.
2. Supports Group 2 only connection and polling I/O data exchange.
3. For I/O mapping, supports a maximum of 32 words input and 32 words output.
4. Supports EDS file configuration in DeviceNet configuration software.
5. Supports all baud rates on DeviceNet bus: 125 kbps, 250 kbps, 500 kbps and extendable baud rate mode.
6. Node address and baud rate can be set in the AC motor drive.
7. Power is supplied from the AC motor drive.

#### Specifications

##### DeviceNet Connector

Interface	5-PIN open pluggable connector. PIN interval: 5.08 mm
Transmission method	CAN
Transmission cable	Shielded twisted-pair cable (with 2 power cables)
Transmission speed	125 kbps, 250 kbps, 500 kbps and extendable baud rate mode
Network protocol	DeviceNet protocol

##### AC Motor Drive Connection Port

Interface	24 PIN communication terminal
Transmission method	SPI communication
Terminal function	<ol style="list-style-type: none"> <li>1. Communication module communicates with the AC motor drive through this port.</li> <li>2. The AC motor drive supplies power to communication module through this port.</li> </ol>
Communication protocol	Delta HSSP protocol

## Electrical Specification

Power supply voltage	15 V <sub>DC</sub> (supplied by the AC motor drive)
Insulation voltage	500 V <sub>DC</sub>
Communication cable power consumption	0.85 W
Power consumption	1 W
Weight	23 g

## Environment

Noise immunity	ESD (IEC 61800-5-1, IEC 6100-4-2) EFT (IEC 61800-5-1, IEC 6100-4-4) Surge Test (IEC 61800-5-1, IEC 6100-4-5) Conducted Susceptibility Test (IEC 61800-5-1, IEC 6100-4-6)
Operation / storage	Operation: -10–50°C (temperature), 90% (humidity) Storage: -25–70°C (temperature), 95% (humidity)
Shock / vibration resistance	International standards: IEC 61800-5-1, IEC 60068-2-6 / IEC 61800-5-1, IEC 60068-2-27

## DeviceNet Connector

PIN	Signal	Color	Definition
1	V+	Red	24 V <sub>DC</sub>
2	H	White	Signal+
3	S	-	Ground
4	L	Blue	Signal-
5	V-	Black	0 V

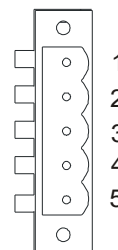

## ■ LED Indicator & Troubleshooting

There are two LED indicators on the CMM-DN02: NS LED and MS LED. NS LED and MS LED are dual-color LEDs, displaying the connection status and error messages of the communication module.

### NS LED

LED status	Indication	Corrective Action
Off	No power supply or the CMM-DN02 does not pass the MAC ID test.	<ol style="list-style-type: none"> <li>1. Check the power to the CMM-DN02 and see if the connection is normal.</li> <li>2. Make sure there is at least one node on the bus.</li> <li>3. Check if the baud rate of the CMM-DN02 is the same as that of the other nodes.</li> </ol>
Green light flashes	The CMM-DN02 is on-line but does not connect to the master.	<ol style="list-style-type: none"> <li>1. Configure the CMM-DN02 to the scan list of the master.</li> <li>2. Re-download the configured data to the master.</li> </ol>

Green light on	The CMM-DN02 is on-line and normally connects to the master.	No action is required.
LED status	Indication	Corrective Action
Red light flashes	The CMM-DN02 is on-line, but I/O connection is timed-out.	<ol style="list-style-type: none"> <li>1. Check if the network connection is normal.</li> <li>2. Check if the master operates normally.</li> </ol>
Red light on	<ol style="list-style-type: none"> <li>1. Broken communication</li> <li>2. MAC ID test failure</li> <li>3. No network power supply.</li> <li>4. CMM-DN02 is off-line.</li> </ol>	<ol style="list-style-type: none"> <li>1. Make sure all MAC IDs on the network are unique.</li> <li>2. Check if the network installation is normal.</li> <li>3. Check if the baud rate of the CMM-DN02 is the same as that of the other nodes.</li> <li>4. Check if the node address of the CMM-DN02 is illegal.</li> <li>5. Check if the network power supply is normal.</li> </ol>

**MS LED**

LED status	Indication	Corrective Action
Off	No power supply or device is off-line	Check the power supply of the CMM-DN02 and see if the connection is normal.
Green light flashes	Waiting for I/O data	Switch the master PLC to RUN status.
Green light on	I/O data is normal	No action is required.
Red light flashes	Mapping error	<ol style="list-style-type: none"> <li>1. Reset the CMM-DN02.</li> <li>2. Re-power the AC motor drive.</li> </ol>
Red light on	Hardware error	<ol style="list-style-type: none"> <li>1. See the fault codes displayed on the keypad and find the causes.</li> <li>2. Return the unit to the factory for repair if necessary.</li> </ol>
Orange light flashes	The CMM-DN02 is connecting with the AC motor drive.	If the flashing lasts for a long period of time, turn off the power to check if the CMM-DN02 and the AC motor drive install correctly and are normally connected to each other.

## 8-4 CMM-EIP02

### Product Profile

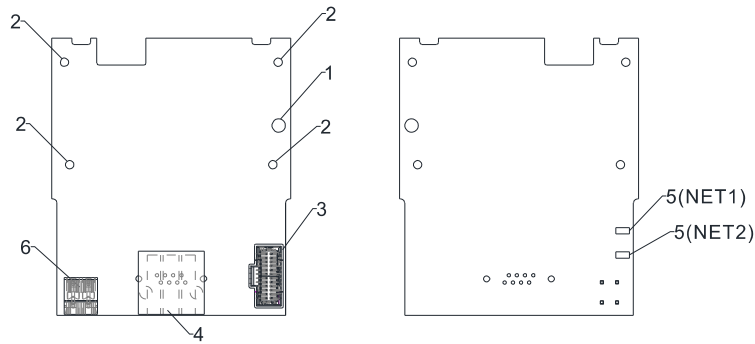

1. Screw fixing hole
2. Positioning hole
3. AC motor drive connection port
4. Communication port
5. Indicator NET1, NET2
6. Ground terminal block

Wire gauge: 0.25–0.5 mm<sup>2</sup> [24–20 AWG]

Stripping length: 7–8 mm

Screw torque: 2 kg-cm / [1.7 lb-in.] / [0.2 Nm]

### Features

1. Supports Modbus TCP and EtherNet/IP protocol
2. 32 / 32 words parameter reading / writing correspondence
3. User-defined corresponding parameters
4. MDI / MDI-X auto-detect
5. E-mail alarm
6. IP filter simple firewall function

### Specifications

#### Network Interface

Interface	RJ45 with Auto MDI / MDIX
Number of ports	1 Port
Transmission method	IEEE 802.3, IEEE 802.3u
Transmission cable	Category 5e shielding 100 M
Transmission speed	10/100 Mbps Auto-Detect
Network protocol	ICMP, IP, TCP, UDP, DHCP, HTTP, SMTP, Modbus over TCP/IP, EtherNet/IP, Delta Configuration

#### Electrical Specification

Power supply voltage	15 V <sub>DC</sub>
Insulation voltage	500 V <sub>DC</sub>
Power consumption	0.8 W
Weight	25 g

Environment

Noise immunity	ESD (IEC 61800-5-1, IEC 61000-4-2) EFT (IEC 61800-5-1, IEC 61000-4-4) Surge Test (IEC 61800-5-1, IEC 61000-4-5) Conducted Susceptibility Test (IEC 61800-5-1, IEC 61000-4-6)
Operation / storage	Operation: -10–50°C (temperature), 90% (humidity) Storage: -25–70°C (temperature), 95% (humidity)
Shock / vibration resistance	International standards: IEC 61800-5-1, IEC 60068-2-6 / IEC 61800-5-1, IEC 60068-2-27

■ **Installation**

Connecting the CMM-EIP02 to the Network

1. Turn off the power of the drive.
2. Open the front cover of the drive.
3. Connect the CAT-5e network cable to the RJ45 port of the CMM-EIP02 (as shown in the right figure).



RJ45 PIN Definition

PIN	Signal	Definition
1	Tx+	Positive pole for data transmission
2	Tx-	Negative pole for data transmission
3	Rx+	Positive pole for data reception
4	--	N/C

PIN	Signal	Definition
5	--	N/C
6	Rx-	Negative pole for data reception
7	--	N/C
8	--	N/C

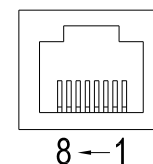

■ **VFD-MS300 Communication Parameter Settings when Connecting to Ethernet**

When you connect the VFD-MS300 to Ethernet, set up the communication parameters based on the table below. The Ethernet master reads and writes the frequency command words and operation command words after you set the communication parameters.

Parameters	Function	Current Setting Value	Description
00-20	Master frequency command source	8	The frequency command is controlled by the communication card.
00-21	Operation command source	5	The operation command is controlled by the communication card.
09-30	Communication decoding method	0	The decoding method for Delta AC motor drive.
09-75	IP configuration	0	0: Static IP 1: Dynamic IP (DHCP)
09-76	IP address 1	192	IP address <u>192</u> .168.1.5
09-77	IP address 2	168	IP address 192. <u>168</u> .1.5

Parameters	Function	Current Setting Value	Description
09-78	IP address 3	1	IP address 192.168.1.5
09-79	IP address 4	5	IP address 192.168.1.5
09-80	Netmask 1	255	Netmask <u>255.255.255.0</u>
09-81	Netmask 2	255	Netmask 255. <u>255.255.0</u>
09-82	Netmask 3	255	Netmask 255.255. <u>255.0</u>
09-83	Netmask 4	0	Netmask 255.255.255. <u>0</u>
09-84	Default gateway 1	192	Default gateway <u>192.168.1.1</u>
09-85	Default gateway 2	168	Default gateway 192. <u>168.1.1</u>
09-86	Default gateway 3	1	Default gateway 192.168. <u>1.1</u>
09-87	Default gateway 4	1	Default gateway 192.168.1. <u>1</u>

## ■ LED Indicator & Troubleshooting

There are two LED indicators on the CMM-EIP02: POWER LED and LINK LED. POWER LED displays the status of the working power. LINK LED displays the connection status of the communication.

### LED Indicators

LED	Status	Indication	Corrective Action	
POWER	Green	On	Power supply in normal status	No action is required.
		Off	No power supply	Check the power supply.
LINK	Green	On	Network connection in normal status	No action is required.
		Flashes	Network in operation	No action is required.
		Off	Network not connected	Check if the network cable is connected.

### Troubleshooting

Abnormality	Cause	Corrective Action
POWER LED off	The AC motor drive is not powered.	Check the power of the AC motor drive, and see if the power supply is normal.
	The CMM-EIP02 is not connected to the AC motor drive.	Ensure that the CMM-EIP02 is connected to the AC motor drive.
LINK LED off	The CMM-EIP02 is not connected to network.	Ensure that the network cable is correctly connected to network.
	Poor contact to the RJ45 connector	Ensure that the RJ45 connector is connected to the Ethernet port.
Cannot find communication card	The CMM-EIP02 is not connected to the network.	Ensure that the CMM-EIP02 is correctly connected to the network.
	The PC and the CMM-EIP02 are in different networks and blocked by network firewall.	Search by IP or set up relevant settings using the AC motor drive keypad.

Abnormality	Cause	Corrective Action
Cannot open CMM-EIP02 setup page	The CMM-EIP02 is not connected to the network.	Ensure that the CMM-EIP02 is correctly connected to the network.
	Incorrect communication setting in DCISoft	Ensure that the communication setting in DCISoft is set to Ethernet.
	The PC and the CMM-EIP02 are in different networks and blocked by network firewall.	Set up with the AC motor drive keypad.
The CMM-EIP02 setup page opens successfully but webpage monitoring is unavailable	Incorrect network setting in the CMM-EIP02	Check if the network setting for the CMM-EIP02 is correct. For the Intranet setting in your company, please consult your IT staff. For the Internet setting at home, please refer to the network setting instructions provided by your ISP.
Cannot send e-mails	Incorrect network setting in the CMM-EIP02	Check if the network setting for the CMM-EIP02 is correct.
	Incorrect mail server setting	Confirm the IP address for the SMTP-Server.



## 8-5 CMM-COP02

### Product Profile

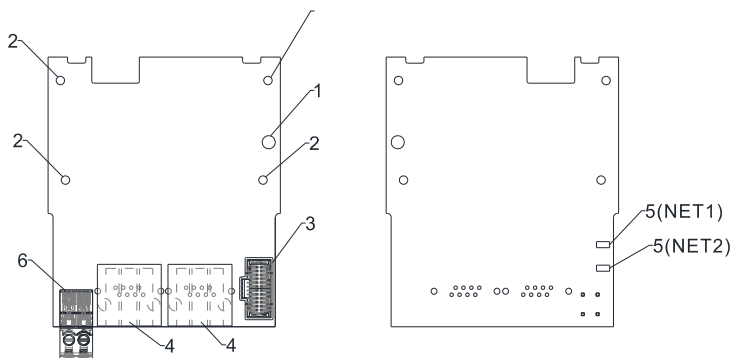

1. Screw fixing hole
2. Positioning hole
3. AC motor drive connection port
4. Communication port
5. Indicator NET1, NET2
6. Ground terminal block

Wire gauge: 0.25–0.5 mm<sup>2</sup> [24–20 AWG]  
 Stripping length: 7–8 mm  
 Screw torque: 2 kg-cm / [1.7 lb-in.] / [0.2 Nm]

### RJ45 Pin Definition



PIN	Signal	Definition
1	CAN_H	CAN_H bus line (dominant high)
2	CAN_L	CAN_L bus line (dominant low)
3	CAN_GND	Ground / 0 V / V-
7	CAN_GND	Ground / 0 V / V-

### Specifications

Interface	RJ45
Number of ports	2 Port
Transmission method	CAN
Transmission cable	CAN standard cable
Transmission speed	1 Mbps; 500 kbps; 250 kbps; 125 kbps; 100 kbps; 50 kbps
Communication protocol	CANopen protocol
Terminating resistance	CMM-COP02 contains terminal resistance accessories. Install the terminal resistance accessories to one of the network connectors when using CMM-COP02.

### CANopen Communication Cable

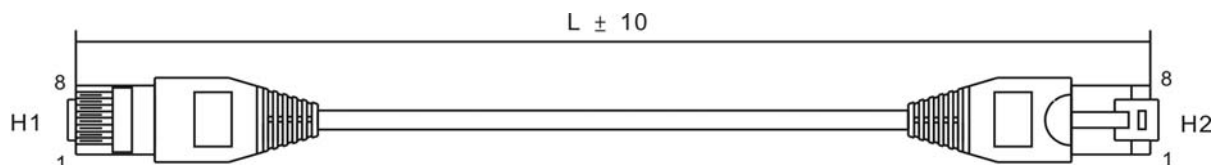

Title	Part No.	L	
		mm	inch
1	UC-CMC003-01A	300	11.8
2	UC-CMC005-01A	500	19.6
3	UC-CMC010-01A	1000	39
4	UC-CMC015-01A	1500	59
5	UC-CMC020-01A	2000	78.7
6	UC-CMC030-01A	3000	118.1
7	UC-CMC050-01A	5000	196.8
8	UC-CMC100-01A	10000	393.7
9	UC-CMC200-01A	20000	787.4

■ **CANopen Dimension**

Model: TAP-CN03

Unit: mm [inch]

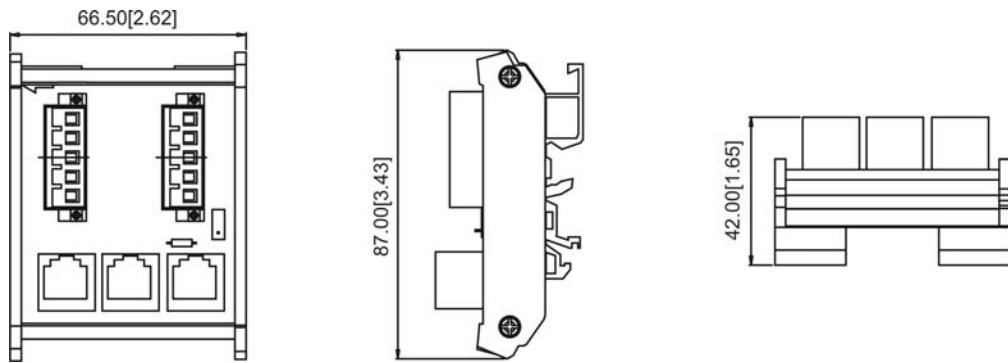

 **NOTE**

For details on how to operate the CANopen communication card, refer to the CANopen operation manual or download the related manuals from Delta's website at <http://www.delta.com.tw/industrialautomation/>.

## 8-6 CMM-EC02

### Product Profile

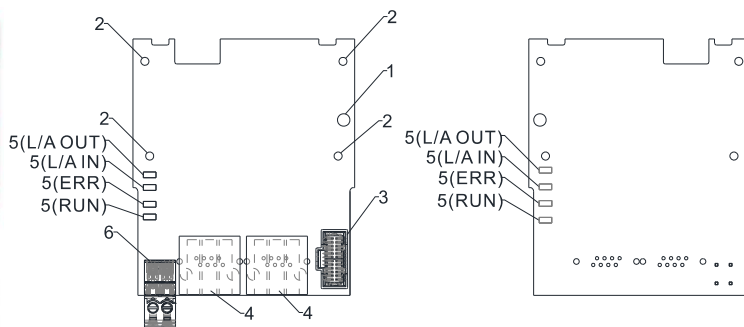

1. Screw fixing hole
2. Positioning hole
3. AC motor drive connection port
4. Communication port
5. Indicator
6. +24V terminal block

Wire gauge: 0.25–0.5 mm<sup>2</sup> [24–20 AWG]

Stripping length: 7–8 mm

Screw torque: 2 kg-cm / [1.7 lb-in.] / [0.2 Nm]

### Features

1. Supports speed mode
2. Supports standard CANopen CiA 402 decoding (CoE)
3. Supports reading and writing parameters
4. Supports stop during disconnection

### Specifications

Network Interface

Interface	RJ45
Number of ports	2 ports
Transmission method	IEEE 802.3, IEEE 802.3u
Transmission cable	Category 5e shielding 100M
Transmission speed	100 Mbps

## 8-7 EMM-BPS02

### ■ Product Profile

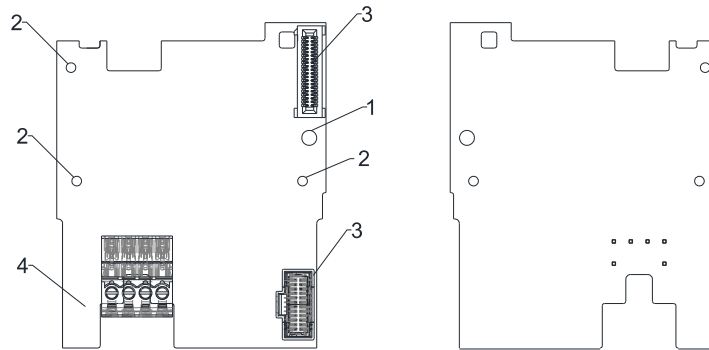

1. Screw fixing hole
2. Positioning hole
3. AC motor drive connection port
4. +24 V terminal block

Wire gauge: 0.25–0.5 mm<sup>2</sup> [24–20 AWG]

Stripping length: 7–8 mm

Screw torque: 2 kg-cm / [1.7 lb-in.] / [0.2 Nm]

### ■ Features

1. Provides external power supply
2. Supports 24 V<sub>DC</sub> input.
3. Supports parameter reading and writing and status monitoring of the drive.

### ■ Specifications

When the drive is only powered by the EMM-BPS02, the EMM-BPS02 ensures the communication works normally, and supports all communication cards and the following functions.

- Parameter reading and writing
- Keypad display
- Keys on the keyboard panel (except the RUN key)
- Analog input with +10 V terminal supply power
- Multi-function inputs (FWD, REV, MI1–MI7) with +24 V terminal or external power supply
- Relay output
- Pulse sequence frequency command

The following functions does not support:

- DFM digital frequency signal output
- AFM multi-function analog voltage output
- PLC functions

## 8-8 Delta Standard Fieldbus Cables

Delta Cables	Part Number	Description	Length
CANopen Cable / Digital Keypad RJ45 Extension Lead	UC-CMC003-01A	CANopen cable, RJ45 connector	0.3 m
	UC-CMC005-01A	CANopen cable, RJ45 connector	0.5 m
	UC-CMC010-01A	CANopen cable, RJ45 connector	1 m
	UC-CMC015-01A	CANopen cable, RJ45 connector	1.5 m
	UC-CMC020-01A	CANopen cable, RJ45 connector	2 m
	UC-CMC030-01A	CANopen cable, RJ45 connector	3 m
	UC-CMC050-01A	CANopen cable, RJ45 connector	5 m
	UC-CMC100-01A	CANopen cable, RJ45 connector	10 m
	UC-CMC200-01A	CANopen cable, RJ45 connector	20 m
DeviceNet Cable	UC-DN01Z-01A	DeviceNet cable	305 m
	UC-DN01Z-02A	DeviceNet cable	305 m
Ethernet / EtherCAT Cable	UC-EMC003-02A	Ethernet / EtherCAT cable, Shielding	0.3 m
	UC-EMC005-02A	Ethernet / EtherCAT cable, Shielding	0.5 m
	UC-EMC010-02A	Ethernet / EtherCAT cable, Shielding	1 m
	UC-EMC020-02A	Ethernet / EtherCAT cable, Shielding	2 m
	UC-EMC050-02A	Ethernet / EtherCAT cable, Shielding	5 m
	UC-EMC100-02A	Ethernet / EtherCAT cable, Shielding	10 m
	UC-EMC200-02A	Ethernet / EtherCAT cable, Shielding	20 m
PROFIBUS Cable	UC-PF01Z-01A	PROFIBUS DP cable	305 m

[This page intentionally left blank]