

ETP HYDRO-GRIP® PENCIL HSK Form F - DIN 69893

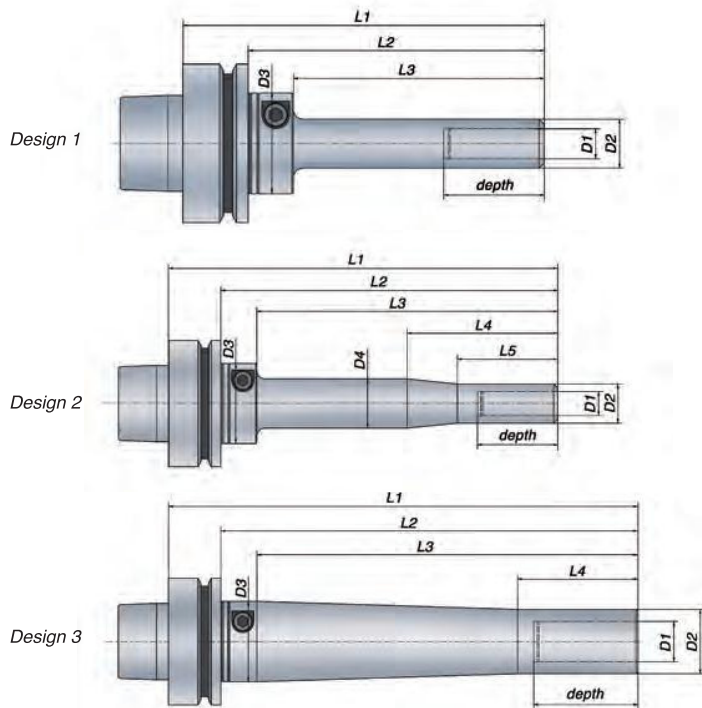

Metric range

Technical Specification HSK form F

Design	HSK size	Part no.	Item description	Dimensions, mm											T* Nm	Weight kg	G 2.5 at rpm	
				D1	D2	D3	D4	L1	L2	L3	L4	L5	depth					
● 1	63	684400	HG PENCIL-6x50/HSK63F	6	12	40		94	68	50					40	12-22	0.8	25 000
● 1		684440	HG PENCIL-12x50/HSK63F	12	19.5	40		94	68	50					40	60-125	0.9	25 000
● 1		684450	HG PENCIL-12x100/HSK63F	12	19.5	40		144	118	100					40	60-125	1	15 000
● 2		684460	HG PENCIL-12x150/HSK63F	12	19.5	40	24.5	194	168	150	75	50		40	60-125	1.2	10 000	
● 3		684490	HG PENCIL-20x110/HSK63F	20	32	40		154	128	110	60			52	260-425	1.4	20 000	
● 3		684500	HG PENCIL-20x190/HSK63F	20	32	40		234	208	190	60			52	260-425	2.1	10 000	

Inch range

Technical Specification HSK form F

Design	HSK size	Part no.	Item description	Dimensions, inch											T* ft-lb	Weight kg	G 2.5 at rpm	
				D1	D2	D3	D4	L1	L2	L3	L4	L5	depth					
● 1	63	684540	HG PENCIL-1/2"x50/HSK63F	0.500	0.768	1.575		3.701	2.677	1.969					1.575	55-105	0.9	25 000
● 1		684550	HG PENCIL-1/2"x100/HSK63F	0.500	0.768	1.575		5.669	4.646	3.937					1.575	55-105	1	15 000
● 2		684560	HG PENCIL-1/2"x150/HSK63F	0.500	0.768	1.575	0.965	7.638	6.614	5.906	2.953	1.969		1.575	55-105	1.2	10 000	
● 3		684590	HG PENCIL-3/4"x110/HSK63F	0.750	1.260	1.575		6.063	5.039	4.331	2.362			2.047	192-314	1.4	20 000	
● 3		684600	HG PENCIL-3/4"x190/HSK63F	0.750	1.260	1.575		9.213	8.189	7.480	2.362			2.047	192-314	2.1	10 000	

*) T = Min. and Max. transmittable torque using a h6 cylindrical tool, full depth insert. For additional information see section Technical Information.

- From stock
- On request

Information:

- Runout accuracy < 0.004 mm at 2.5 x D1 (max. 50 mm)
 ≤0.00016 inch at 2.5x D1 (max. 1.969 inch)
 ≤0.007 mm at 2.5 x D1 at length L1 > 125 mm
 ≤0.00028 inch at 2.5x D1 at length L1 > 4.921 inch
- Tool shank h6 or h7 can be used
- Coolant through on all holders

Accessories:

Use preset Torque Wrench, 6 Nm, to ensure correct mounting of tools. Part no. 19050

ETP HYDRO-GRIP PENCIL can be used with reducing sleeves.

For additional information see section Accessories.

